



GAZCO

# STUDIO

GAS FIRES



# Aesthetics Performance Versatility

These are the elements that define the Studio range. Effortlessly becoming the focal point of your interior, a Studio fire brings far more than just heat to your home.

Each fire is designed to seamlessly blend beauty and performance, offering superb flame visuals and high efficiency heating. All at the touch of a button.

Presented with a variety of elegant styling options, the Studio range lets you tailor your fire to complete your home.



**Cover image:** Studio 3 Edge 'Cool Wall' with Log-effect fuel bed and Vermiculite lining. See page 62 for further details on 'Cool Wall' kits.





Studio 3, Expression frame in Graphite with Log-effect fuel bed and Vermiculite Lining.

# Relax - it's a Gazco Fire...

When you choose Gazco, quality and innovative technology are assured. From traditional models to contemporary designs, Gazco is committed to creating the ultimate flame-effect gas and electric fires. Our UK research and development laboratories are amongst the most advanced in the world, ensuring that the very latest innovations are incorporated into our appliances.

Gazco is an ISO9001 and ISO14001 accredited company. Our rigorous quality control system ensures that all our appliances are safety checked and that

they comply with the appropriate regulations, with all stoves in this brochure bearing the CE mark. Similarly, our environmental management systems ensure we work in a sustainable manner, whilst endeavouring to protect the environment by minimising any possible impact from our operations.

With over 30 years of proven experience building quality Gas fires, you can be confident that when you select a Gazco fire, you are getting the best of British design, engineering and manufacturing.



Studio 2, Steel 2 frame in Graphite with Pebble & Stone fuel bed and EchoFlame Black Glass lining.



**WIN** the cost of your product back!

by registering your product online for your free extended warranty. See page 71 for more details.

## Expert Retailer Network

We take great care to ensure that our fires are designed, tested and manufactured to the highest possible quality and safety standards.

We are equally careful to make certain our fires are sold and installed correctly to ensure they provide you with years of enjoyment. Our products are only available from experienced, independent retailers who will be happy to show you a selection of models locally in their showrooms, often fully operational. These independent retailers will discuss your individual requirements, including both technical (such as sizing the heat output to your room and advising on your flue type) and design, to ensure that you select the most appropriate product for your home.

Our experienced retailers will also be able to advise on, or assist with, the installation process as well as help provide any after-sales support and servicing your appliance may require in the future.

Whilst we encourage our retailers to promote fireplace products and their outlets via the internet, we do not believe suitable levels of customer care and satisfaction can be obtained from purchasing the product only online and we would strongly recommend that you consider this when undertaking your research and making a purchasing decision. Furthermore, please be aware that we do not offer technical support (beyond our statutory responsibilities) for products bought via nationwide online sales, where this support would normally be offered by one of our qualified, independent retailers.

Find your local Expert Retailer

Find your nearest retailer by visiting:  
[www.gazco.com/retailers](http://www.gazco.com/retailers)



## Five Year Extended Warranty

Your Gazco Expert Retailer will provide you with a Two Year Warranty for your new gas fire. This can be extended to a Five Year Warranty by registering your fire with Gazco. Please note, these warranties exclude certain consumable parts. Fires purchased outside of Gazco's Expert Retailer Network will carry a standard 1 Year non-extendable Warranty. Full warranty terms and conditions are available to view at [www.gazco.com](http://www.gazco.com).





# Contents

How to Choose your Studio fire .....	09
Studio Flue Options.....	10
Fire Types & Sizes .....	12
Fuel Effects .....	14
Frames and Surround Options .....	16
Lining Options .....	18

## Studio Inset

Studio 1 .....	20
Studio 2 .....	24
Studio 3 .....	28

## Studio Open Fronted

Studio 1, 2 & 3 Open Fronted .....	32
------------------------------------	----

## Studio Slimline

Studio Slimline .....	34
Studio 1 Slimline .....	36
Studio 2 Slimline .....	38
Studio Slimline Zero Clearance.....	40
Studio Slimline Monaco .....	44

## Studio Duplex

Studio Duplex .....	46
---------------------	----

## Studio Freestanding

Studio Freestanding .....	50
Studio 1 Freestanding .....	52
Studio 2 Freestanding .....	54
Studio Summary and options.....	56
Technical Information .....	58



Studio 3, Profil frame in Polished Stainless Steel finish with Driftwood-effect fuel bed and EchoFlame Black Glass lining.





8 Studio 2, Edge 'Cool Wall' with Driftwood-effect fuel bed and Vermiculite lining. See page 62 for further details on Cool Wall kits.



# How to choose your Studio fire...

With a wealth of design options complemented by a choice of sizes, linings and fuel bed effects, these beautifully contemporary fires will add instant style and presence to any modern interior. The following pages will guide you through the wide selection of possibilities and styling options that are synonymous with the Studio range...

## 1 Step 1 Flue Options

Studio fires are available in conventional flue and balanced flue versions, allowing you to install your fire with or without a chimney.



Pages 10 - 11

## 2 Step 2 Types & Sizes

Studio fires can be selected in a variety of different types and sizes including Slimline, double-sided and even stove versions, depending on which flue type is required.



Pages 12-13

## 3 Step 3 Fuel Effects

Many Studio fires can be customised with a range of fuel effects to transform the flames, including realistic logs and stylish stone.



Pages 14-15

## 4 Step 4 Frames

Studio fires can be styled to perfectly suit your décor. Choose to install your Studio as a frameless Edge or with one of the many stylish steel and glass frames available.



Pages 16-17

## 5 Step 5 Linings

Choose the perfect lining to enhance your Studio's flames from the variety of options available. Each lining offers a backdrop for the stunning visuals.



Pages 18-19

# Studio Flue Types

Studios fires can be installed with or without a chimney, depending on the type of fire. Suitable for a wide range of homes, this versatile fire collection can be configured to suit your requirements.



# Conventional Flue

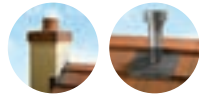

Conventional flue Studio fires are designed to use an existing brick or stone chimney, or if your home does not have a chimney, a prefabricated chimney system that can be fitted when your fire is installed.

A prefabricated chimney system creates the same circulation of heated air as a brick or stone chimney and exits the roof as a metal flue.

Conventional flue Studio fires include the Open Fronted range as well as the high efficiency Glass Fronted range which incorporates both inset and freestanding fires.

## Key Features

1. Conventional Flue connection
2. Linerless installation with no need for additional adapters†
3. Open Fronted or Glass Fronted models
4. Choice of fuel effects†
5. Choice of linings†
6. Choice of frame styles
7. Convected and radiant heat†
8. Convected heat system outlet†
9. Simple drop down door for easy maintenance access†
10. Remote control included\*
11. External battery holders for ease of battery change
12. Optional mains adaptor

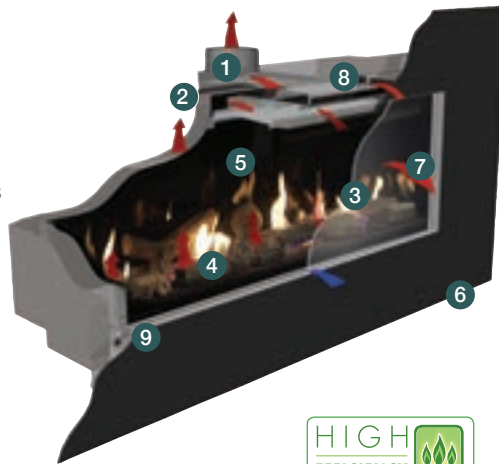

\* Illustrated below  
† Glass fronted models only

# Balanced Flue



Balanced flue Studio fires do not require a chimney. Instead, a twin-walled pipe going from the fire to the exterior of the property draws in combustion air whilst also removing flue gases. Depending on which fire is selected, the twin-wall pipe can exit horizontally through an outside wall or vertically through the roof.

Balanced flue Studios are high efficiency Glass Fronted fires and are completely sealed from the room they are installed in. These include the Studio Inset and Freestanding ranges, Studio 2 Duplex and Studio Slimline range.

## Key Features

1. Balanced Flue connection
2. Variety of flueing options for location flexibility
3. Glass Fronted
4. Choice of fuel effects
5. Choice of linings
6. Choice of frame styles
7. Convected and radiant heat
8. Convected heat system outlet
9. Simple drop down door for easy maintenance access
10. External battery holders for ease of battery change
11. Programmable Thermostatic remote control included\*
12. Optional mains adaptor

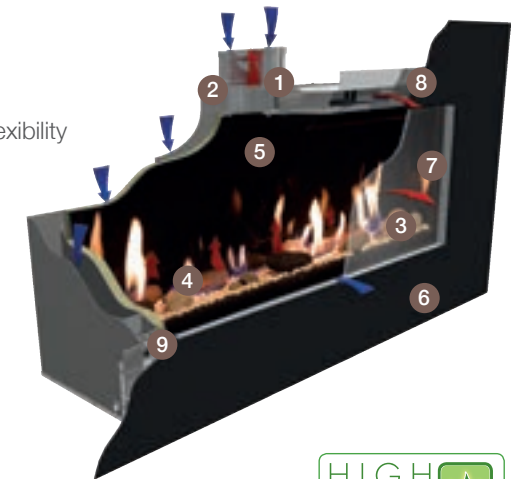

\* Illustrated below

For further information on your flue and air vent requirements please see page 68.

## Remote Controls

All Open Fronted fires in the Studio range are supplied with our Standard remote control, allowing you to operate everything from ignition to flame height and heat output from the comfort of your sofa. The Glass Fronted Studios come complete with a Programmable Thermostatic remote that also includes the additional benefits of a programmable timer and thermostatic controls, ensuring that whenever you return home, your house will always be warm and welcoming. Studio fires have an external battery which can be discretely and conveniently located up to 3 metres away from the fire. Alternatively you can choose the optional mains adaptor for an installation without batteries. Open Fronted Studios also have a wall mounted, flat Touch Control Panel.



**Left:** Standard remote for Open Fronted Studio fires

**Right:** Programmable Thermostatic remote for Glass Fronted Studio fires



# Studio Types & Sizes

For optimal versatility, Studio fires are available in a choice of types, sizes and heat outputs to suit a variety of interior spaces. Choose from Open Fronted or high efficiency Glass Fronted, double sided or specially designed Slimline models for cavity wall installations.



Studio 2 Edge+ with Pebble & Stone fuel bed and Vermiculite lining

## Studio 1 (page 20)

The Studio 1 is the smallest fire in the range and can be selected in either Open Fronted (page 32) or high efficiency Glass Fronted versions. Studio 1 Glass Fronted fires are offered in either conventional or balanced flue models with a choice of fuel effects and linings. A freestanding, Glass Fronted stove version of this stunning fire is also available. See pages 50-55.

## Studio 2 (page 24)

Available as either an Open Fronted (page 32) or high efficiency Glass Fronted fire, the mid-sized Studio 2 offers impressive flames and heat output. Studio 2 Glass Fronted fires come in conventional or balanced flue options with a choice of fuel effects and lining options. A freestanding Glass Fronted stove version, with a choice of finishes, offers an ultra-contemporary alternative. See pages 50-55.

## Studio 3 (page 28)

Presenting a truly breath-taking view of the expansive flame visuals, the Studio 3 is the largest size in the range and can be selected as an Open Fronted (page 32) or Glass Fronted fire. The Glass Fronted version can be tailored with a choice of linings and fuel effects to suit your interior.



Studio 1 Balanced flue with Pebble & Stone fuel bed & EchoFlame Black Glass lining



Studio 2 Balanced flue with Log-effect fuel bed & Black Reeded lining



Studio 3 Balanced flue with Driftwood-effect fuel bed & Vermiculite lining

## Studio 1 & 2 Slimline (page 34)

The high efficiency Studio Slimline fires have been specifically designed for cavity wall installations. Offered in a choice of two sizes, they feature an ultra-slim profile whilst still providing a superb view of the flames. Available with a choice of white stone, glass bead or realistic log fuel beds; these Glass Fronted fires provide a generous heat output and are supplied complete with a Balanced Flue rear termination installation kit.



## Studio 2 Duplex (page 46)



The double-sided Studio 2 Duplex allows the flame visuals to be enjoyed from either side. Producing up to 7.9kW of heat output, this Glass Fronted balanced flue fire has a highly realistic Log-effect fuel bed.

# Studio Fuel Effects

The fuel effects in each Studio fire are designed to create a stunning centrepiece, whether you choose the traditional ambience of the log or driftwood or the contemporary minimalism of pebbles and stones.



Studio 2, Profil frame in Anthracite with Log-effect fuel bed and EchoFlame Black Glass lining



## Log-effect (Glass Fronted)



Glass Fronted Studio fires can also be selected with the highly realistic, hand-painted Log-effect fuel bed, for a natural woodburning aesthetic that looks just like a real log fire. Tall flames jump and flow between the logs for a mesmerising focal point.

## Driftwood-effect (Glass Fronted)



Available for Glass Fronted Studio 1, 2 & 3 fires, this alternative wood-effect fuel bed creates an authentic looking driftwood composition. Presented on a bed of stones, each piece is precisely painted to resemble naturally weathered beach timber.

## Pebble & Stone (Glass Fronted)



Ceramic pebbles positioned on a bed of stones offer an ambient beach vibe with this beautifully contemporary fuel effect for selected Glass Fronted Studio fires. Featuring tall flames that dance across the white stones, this stylish fuel effect makes for a striking, designer statement.

## White Stones or Glass Beads (Open Fronted & Slimline)



Open Fronted Studio fires feature a contemporary ribbon of flames on a bed of white stones, which can be upgraded to black or clear glass beads. Echoing the fire's clean form, these minimalist fuel effects create a designer statement that can be appreciated with or without the flames.



# Frame Options

Studio fires have many frame options available, including a number of different styles in steel or glass, as well as various colours and finishes. These stunning frame options have all been designed specifically to complement this contemporary fire range and offer you a spectrum of styling possibilities.



Studio 2 Open Fronted Conventional Flue,  
Glass frame with Black Glass Bead fuel bed

	Studio 1	Studio 2	Studio 3	Studio Slimline	Studio Duplex
Edge	✓	✓	✓	✓	✓
Edge+	✓	✓	✓	✗	✓
Profil	✓	✓	✓	✓	✓
Expression	✓ <sup>#</sup>	✓ <sup>#</sup>	✓ <sup>#</sup>	✓	✓
Steel 2	✓ <sup>#</sup>	✓	✗	✓	✓
Glass	✓	✓	✓ <sup>^</sup>	✓	✓
Verve	✓	✓	✓ <sup>^</sup>	✓	✓
Sorrento	✗	✗	✗	✗	✗
ZC Glass & Steel	✗	✗	✗	✓	✗
Monaco	✗	✗	✗	✓ <sup>*</sup>	✗
Studio Freestanding Complete product	✓	✓	✗	✗	✗

<sup>#</sup> Suitable for Glass Fronted Studios only    <sup>\*</sup> Studio 1 Slimline only.    <sup>^</sup> Suitable for Open Fronted Studios only.

Edge    Pages 8, 10, 18, 21, 22, 26,  
33, 38, 48 & 58



Edge+    Pages 12, 21, 24, 28, 30,  
39, 49 & 56



Freestanding

Pages 19, 50 - 55



White or Black Steel front

## Verve

Pages 25, 32 & 37



Graphite

Aerial View Below



## Steel 2

Pages 4, 27 & 39



Graphite

## Expression

Pages 3, 23, 26, 29 & 36



Graphite

## Glass

Pages 16, 19, 20, 35 & 46



Black Glass

## Profil

Pages 7, 14, 22, 25, 28, 31, 32, 34, 36, 48 & Front Cover



Anthracite or Polished Stainless Steel

## Monaco

Page 44



Concrete with Black Granite top

## ZC Glass

Pages 40 - 43



Black or White Glass front with Graphite Steel rear

## ZC Steel

Pages 40 & 43



Graphite front and rear



# Lining Options

Studio gas fires are highly customisable and their choice of stylish lining options is no exception. Depending on the model, each fire can be styled to your tastes with a range of different linings that offer a dramatically different aesthetic for your fire.



Studio 2, Edge 'Cool Wall' with Log-effect fuel bed and EchoFlame Black Glass Lining. See page 62 for further details on Cool Wall kits.



	Echoflame Black Glass	Vermiculite	Black Reeded	Brick Effect	Black Steel	Polished Black Granite
Studio 1, 2 & 3 (Glass Fronted)	✓	✓	✓	✗	✗	✗
Open Fronted Studio	✗	✗	✗	✗	✓	✓ (Upgradeable)
Studio Slimline	✓	✓	✓	✓	✗	✗
Studio Duplex	✗	✓	✓	✗	✗	✗
Studio Freestanding	✓	✓ (Optional)	✓ (Optional)	✗	✗	✗

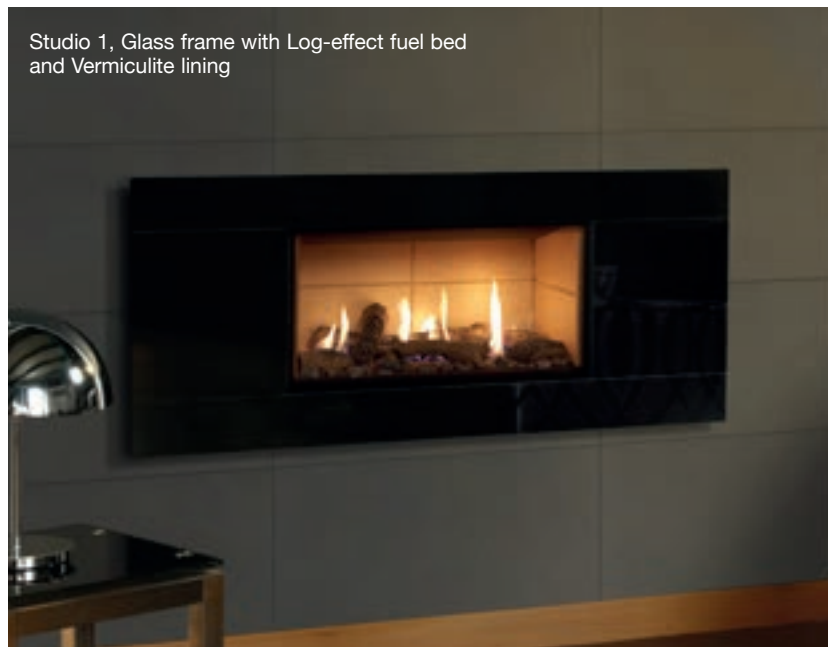

Studio 1, Glass frame with Log-effect fuel bed and Vermiculite lining



Studio 1 Freestanding with White front and bench, Log-effect fuel bed and Black Reeded lining



Studio 1, Glass Frame with Pebble & Stone fuel bed and Black Reeded lining



# Studio 1

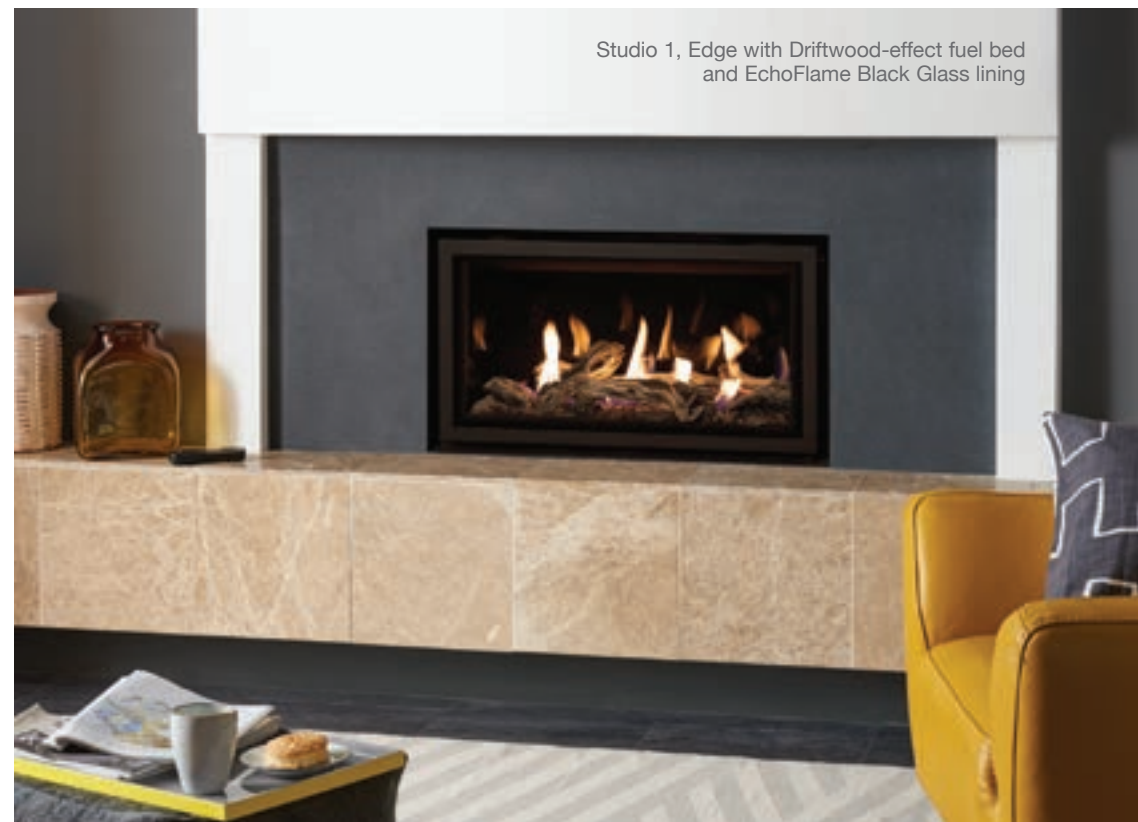

	Efficiency & Heat Output			Chimney or Flue Options			Gas Type		Fuel Bed			Linings			Control
	E% <sup>†</sup>	EFFICIENCY CLASS	kW	BRICK CHIMNEY	PRE-FABRICATED	BALANCED FLUE	NATURAL GAS	LPG GAS	LOGS	DRIFTWOOD	PEBBLE & STONE	VERMICULITE	BLACK REEDED	BLACK GLASS	PROGRAMMABLE THERMOSTATIC REMOTE
Studio 1 Glass Fronted Conventional Flue	72%	E	4.60kW	✓	✓	✗	✓	✓	✓	✓	✓	✓	✓	✓	✓
Studio 1 Glass Fronted Balanced Flue	92%	A	5.30kW	✗	✗	✓	✓	✓	✓	✓	✓	✓	✓	✓	✓

† Efficiency and heat output figures are based upon the maximum achieved in the options available. For more detailed technical information, including firebox dimensions and installation requirements, see pages 59 - 62.

Studio Open Fronted fires are shown on pages 32 - 33.

**Frame Options**  
For the complete selection of frames available with Studio fires see pages 16 - 17.

# Studio 1 (continued)



Studio 1, Edge with Pebble & Stone fuel bed and Vermiculite lining



Studio 1, Profil in Stainless Steel with Log-effect fuel bed and Black Reeded lining

		Efficiency & Heat Output			Chimney or Flue Options			Gas Type		Fuel Bed			Linings			Control
		E% <sup>†</sup>	EFFICIENCY CLASS	kW	BRICK CHIMNEY	PRE-FABRICATED	BALANCED FLUE	NATURAL GAS	LPG GAS	LOGS	DRIFTWOOD	PEBBLE & STONE	VERMICULITE	BLACK REEDED	BLACK GLASS	PROGRAMMABLE THERMOSTATIC REMOTE
Studio 1 Glass Fronted Conventional Flue		72%	E	4.60kW	✓	✓	✗	✓	✓	✓	✓	✓	✓	✓	✓	
Studio 1 Glass Fronted Balanced Flue		92%	A	5.30kW	✗	✗	✓	✓	✓	✓	✓	✓	✓	✓	✓	

† Efficiency and heat output figures are based upon the maximum achieved in the options available. For more detailed technical information, including firebox dimensions and installation requirements, see pages 59 - 62.

Studio Open Fronted fires are shown on pages 32 - 33.

## Frame Options

For the complete selection of frames available with Studio fires see pages 16 - 17.



Studio 1, Expression in Graphite with Driftwood-effect fuel bed and EchoFlame Black Glass lining





Studio 2, Edge+ with Log-effect fuel bed and Vermiculite lining

# Studio 2



	Efficiency & Heat Output			Chimney or Flue Options			Gas Type		Fuel Bed			Linings			Control
	E% <sup>†</sup>	EFFICIENCY CLASS	kW	BRICK CHIMNEY	PRE-FABRICATED	BALANCED FLUE	NATURAL GAS	LPG GAS	LOGS	DRIFTWOOD	PEBBLE & STONE	VERMICULITE	BLACK REEDED	BLACK GLASS	PROGRAMMABLE THERMOSTATIC REMOTE
Studio 2 Glass Fronted Conventional Flue	81%	C	6.20kW	✓	✓	✗	✓	✓	✓	✓	✓	✓	✓	✓	✓
Studio 2 Glass Fronted Balanced Flue	92%	A	7.00kW	✗	✗	✓	✓	✓	✓	✓	✓	✓	✓	✓	✓

**Frame Options**  
For the complete selection of frames available with Studio fires see pages 16 - 17.

<sup>†</sup> Efficiency and heat output figures are based upon the maximum achieved in the options available. For more detailed technical information, including firebox dimensions and installation requirements, see pages 59 - 62.

Studio Open Fronted fires are shown on pages 32 - 33.

# Studio 2 (continued)



Studio 2, Edge 'Cool Wall' with Driftwood-effect fuel bed and Vermiculite lining. See page 62 for further details on Cool Wall kits.



Studio 2, Expression frame in Graphite with Pebble & Stone fuel bed and Black Reeded lining

	Efficiency & Heat Output			Chimney or Flue Options			Gas Type		Fuel Bed			Linings			Control
	E% <sup>†</sup>	EFFICIENCY CLASS	kW	BRICK CHIMNEY	PRE-FABRICATED	BALANCED FLUE	NATURAL GAS	LPG GAS	LOGS	DRIFTWOOD	PEBBLE & STONE	VERMICULITE	BLACK REEDED	BLACK GLASS	PROGRAMMABLE THERMOSTATIC REMOTE
Studio 2 Glass Fronted Conventional Flue	81%	C	6.20kW	✓	✓	✗	✓	✓	✓	✓	✓	✓	✓	✓	✓
Studio 2 Glass Fronted Balanced Flue	92%	A	7.00kW	✗	✗	✓	✓	✓	✓	✓	✓	✓	✓	✓	✓

<sup>†</sup> Efficiency and heat output figures are based upon the maximum achieved in the options available. For more detailed technical information, including firebox dimensions and installation requirements, see pages 59 - 62.

Studio Open Fronted fires are shown on pages 32 - 33.

## Frame Options

For the complete selection of frames available with Studio fires see pages 16 - 17.





Studio 2, Steel 2 frame in Graphite with Log-effect fuel bed and EchoFlame Black Glass lining

# Studio 3

Studio 3, Profil frame in Anthracite with Driftwood-effect fuel bed and Vermiculite lining



Studio 3, Edge+ with Pebble & Stone fuel bed and EchoFlame Black Glass lining



	Efficiency & Heat Output			Chimney or Flue Options			Gas Type		Fuel Bed			Linings			Control
	E% <sup>†</sup>	EFFICIENCY CLASS	kW	BRICK CHIMNEY	PRE-FABRICATED	BALANCED FLUE	NATURAL GAS	LPG GAS	LOGS	DRIFTWOOD	PEBBLE & STONE	VERMICULITE	BLACK REEDED	BLACK GLASS	PROGRAMMABLE THERMOSTATIC REMOTE
Studio 3 Glass Fronted Balanced Flue	92%	A	8.40kW	Pg 32	Pg 32	✓	✓	✓	✓	✓	✓	✓	✓	✓	✓

## Frame Options

For the complete selection of frames available with Studio fires see pages 16 - 17.

<sup>†</sup> Efficiency and heat output figures are based upon the maximum achieved in the options available. For more detailed technical information, including firebox dimensions and installation requirements, see pages 59 - 62.

Studio Open Fronted fires are shown on pages 32 - 33.





Studio 3, Expression frame in Graphite with Log-effect fuel bed and EchoFlame Black Glass lining





Studio 3, Edge+ with Log-effect fuel bed and Vermiculite lining

# Studio 3 (continued)

Studio 3, Profil frame in Anthracite with Driftwood-effect fuel bed and EchoFlame Black Glass lining



	Efficiency & Heat Output			Chimney or Flue Options			Gas Type		Fuel Bed			Linings			Control
	E% <sup>†</sup>	EFFICIENCY CLASS	kW	BRICK CHIMNEY	PRE-FABRICATED	BALANCED FLUE	NATURAL GAS	LPG GAS	LOGS	DRIFTWOOD	PEBBLE & STONE	VERMICULITE	BLACK REEDED	BLACK GLASS	PROGRAMMABLE THERMOSTATIC REMOTE
Studio 3 Glass Fronted Balanced Flue	92%	A	8.40kW	Pg 32	Pg 32	✓	✓	✓	✓	✓	✓	✓	✓	✓	✓

## Frame Options

For the complete selection of frames available with Studio fires see pages 16 - 17.

<sup>†</sup> Efficiency and heat output figures are based upon the maximum achieved in the options available. For more detailed technical information, including firebox dimensions and installation requirements, see pages 59 - 62.

Studio Open Fronted fires are shown on pages 32 - 33.

# Studio 1, 2 & 3 Open Fronted



Studio 1 Open Fronted<sup>A</sup> Conventional Flue, Profil frame in Polished Stainless Steel finish with Clear Glass Bead fuel bed



Studio 2 Open Fronted Conventional Flue, Profil frame in Anthracite with White Stone fuel bed

	Efficiency & Heat Output†		Chimney or Flue Options			Gas Type		Fuel Bed		Linings		Control
	E%	kW	BRICK CHIMNEY	PRE-FABRICATED	BALANCED FLUE	NATURAL GAS	LPG GAS	WHITE STONES	GLASS BEADS <sup>‡</sup>	BLACK STEEL	POLISHED BLACK GRANITE <sup>‡</sup>	STANDARD REMOTE
Studio 1 Open Fronted Conventional Flue 	25%	1.72kW	✓	✓	X	✓	✓	✓	✓	✓	✓	✓
Studio 2 Open Fronted Conventional Flue	25%	2.30kW	✓	✓	X	✓	✓	✓	✓	✓	✓	✓
Studio 3 Open Fronted Conventional Flue	25%	3.40kW	✓	✓	X	✓	✓	✓	✓	✓	✓	✓

**Frame Options**  
 For the complete selection of frames available with Studio Conventional Flue fires please see pages 16 - 17.

Studio Glass Fronted, conventional flue fires are shown on pages 20 - 31.

† Efficiency and heat output figures are based upon the maximum achieved in the options available. For detailed technical information, including firebox dimensions, installation and flue gather requirements, see page 58.

‡ Upgradeable options





# Studio Slimline

Available in two sizes, these slimmer depth fires have been created to allow an easier, quicker and more cost effective installation option, whilst still retaining all the unmistakable characteristics of the Gazco Studio range.



Studio 2 Slimline Balanced Flue, Profil frame in Graphite with Log-effect fuel bed and EchoFlame Black Glass Lining



## A Slimline fire for cavity wall installation

The Glass Fronted Studio Slimline fires have been specifically developed to allow the highly desirable aesthetics of the landscape Studio fires to be achieved in a wider variety of homes by simply recessing into the internal leaf of a cavity wall. Available in two sizes, both come complete with a dedicated rear exit balanced flue termination kit for easy installation - see page 65 for further information. For even more installation possibilities the Monaco surround (see page 44) allows for mounting on to a flat external wall and the Zero Clearance range allows you to install Slimline fires in walls constructed from conventional materials such as studwork and plasterboard (see page 40).

Although compact in design, these highly efficient fires have a generous heat output which is easily controlled with the Programmable Thermostatic remote control.

## Key Features

1. Shallow firebox depth of just 155mm
2. Balanced Flue connection
3. Choice of linings
4. Choice of contemporary or realistic fuel
5. Choice of frame styles
6. Convected and radiant heat
7. Convected heat system outlet
8. Programmable Thermostatic remote control
9. Rear exit Balanced Flue Termination Kit included\*
10. External battery holder for ease of battery change\*
11. Optional mains adaptor\*

\* Not illustrated



## Slimline Frame Options

Studio Slimline fires can be styled to your interior with the one of the many high quality frames available, a selection of which are shown on these pages and overleaf. Alternatively, for a minimalist look, the frameless Edge design allows for a striking, hole-in-the-wall installation. For a complete frame style reference please see pages 16-17.

## Fuel Effects and Lining Options

To further extend your options for personalisation, there is a choice of four linings and three fuel effects available for the Studio Slimline fires. Each of the lining choices, including contemporary Vermiculite, timeless Black Reeded, classic Brick-effect or depth-enhancing EchoFlame Black Glass can be paired with either realistic logs or contemporary white stone fuel effects. For further styling versatility, the white stones fuel bed can be upgraded to glass bead effects.



Vermiculite Lining



Black Reeded Lining



Brick-effect Lining



EchoFlame Black Glass Lining

With each combination offering a significantly different appearance to the fire, you can be sure to select the perfect combination of fuel effect, lining and frame style to suit your interior decor.



Studio 1 Slimline Balanced Flue, Glass frame with White Stone fuel bed & Black Reeded Lining. Inset: Upgradeable Black & Clear Glass Bead fuel effects.



# Studio 1 Slimline



Studio 1 Slimline Balanced Flue, Expression frame in Graphite with Log-effect fuel bed and EchoFlame Black Glass Lining



Studio 1 Slimline Balanced Flue, Profil frame in Anthracite with White Stone fuel bed and Black Reeded Lining

	Efficiency & Heat Output†			Chimney or Flue Options			Gas Type		Fuel Bed		Linings				Control
	E%	ENERGY EFFICIENCY CLASS	kW	BRICK CHIMNEY	PRE-FABRICATED	BALANCED FLUE	NATURAL GAS	LPG GAS	LOGS	WHITE STONES	BRICK EFFECT	VERMICULITE	BLACK REEDED	BLACK GLASS	PROGRAMMABLE THERMOSTATIC REMOTE
Studio 1 Slimline Balanced Flue	82%	C	3.80kW	X	X	✓	✓	✓	✓	✓	✓	✓	✓	✓	✓

† Efficiency and heat output figures are based upon the maximum achieved in the options available. For more detailed technical information, including firebox dimensions and installation requirements, see pages 64 - 65.

## Frame Options

For the complete selection of frames available with Studio fires please see pages 16 - 17.



Studio 1 Slimline Balanced Flue, Verve Frame in Graphite with Log-effect fuel bed and Brick-effect Lining



Studio 2 Slimline Balanced Flue, Edge with Log-effect fuel bed and EchoFlame Black Glass Lining



# Studio 2 Slimline



Studio 2 Slimline Balanced Flue, Steel 2 Frame in Graphite with Log-effect fuel bed and Brick-effect Lining



Studio 2 Slimline Balanced Flue, Profil Frame in Anthracite with Log-effect fuel bed and Vermiculite Lining

	Efficiency & Heat Output†			Chimney or Flue Options			Gas Type		Fuel Bed		Linings				Control
	E%	ENERGY EFFICIENCY CLASS	kW	BRICK CHIMNEY	PRE-FABRICATED	BALANCED FLUE	NATURAL GAS	LPG GAS	LOGS	WHITE STONES	BRICK EFFECT	VERMICULITE	BLACK REEDED	BLACK GLASS	PROGRAMMABLE THERMOSTATIC REMOTE
Studio 2 Slimline Balanced Flue	82%	C	5.00kW	X	X	✓	✓	✓	✓	✓	✓	✓	✓	✓	✓

† Efficiency and heat output figures are based upon the maximum achieved in the options available. For more detailed technical information, including firebox dimensions and installation requirements, see pages 64 - 65.

**Frame Options**  
 For the complete selection of frames available with Studio fires please see pages 16 - 17.

# Studio Slimline Zero Clearance Range

Studio 1 Slimline Balanced Flue, ZC Steel frame in Graphite with Log-effect fuel bed and Black Reeded Lining



New Studio Slimline Zero Clearance frame kits increase your installation possibilities around the home by allowing for simpler and easier fitting of Slimline fires into existing walls.

Unlike many gas fires, the Slimline Zero Clearance range does not need a specially constructed non-combustible wall to house the appliance. The Zero Clearance Frame kit includes an enclosure that houses the fire and circulates air around the appliance, reducing the heat transferred to the installation wall by directing it back into the room.

This means you can choose to fit your Slimline fire into walls with standard plasterboard and stud-work thanks to the Zero Clearance kit's ability to keep wall temperatures to a minimum. Zero Clearance Slimline fires are available in both Studio 1 and 2 Sizes

## Key Features

1. Zero clearance box enclosure to reduce wall temperatures (included with frame)
2. Shallow firebox depth of just 155mm
3. Balanced flue connection
4. Choice of linings
5. Choice of contemporary or realistic fuel effects
6. Choice of new Zero clearance box frame styles
7. Convected and radiant heat system
8. Convected heat system outlet
9. Programmable Thermostatic remote control
10. Rear exit balanced flue termination kit included\*
11. External battery holder for ease of battery change\*
12. Optional mains adaptor\*

\* Not illustrated





Studio 2 Slimline Balanced Flue, ZC Glass frame in Black Glass with Log-effect fuel bed and Vermiculite Lining



# Studio Slimline Zero Clearance Range (continued)



Studio 2 Slimline Balanced Flue, ZC Steel frame in Graphite with Log-effect fuel bed and EchoFlame Black Glass Lining



Studio 1 Slimline Balance Flue, ZC Glass frame in White Glass with Log-effect fuel bed and Brick-effect Lining

Slimline Zero Clearance Frames offer unique, eye-catching and functional styling options. Cleverly designed to not only enhance the look of your fire, each frame also allows cool air to be drawn from the room and around the Zero Clearance enclosure. The air is then heated and convected back into the room, reducing the surrounding wall temperatures.

Frame options are available in two, specifically designed frame styles exclusive to the Zero Clearance Slimline range. Choose from ZC Steel in a Graphite finish or ZC Glass in a choice of either White Glass or Black Glass, both providing an exceptional finish that completely covers the fire's installation edge whilst creating a stylish focal point.

Studio 2 Slimline Balanced Flue, ZC Glass frame in Black Glass with Log-effect fuel bed and Brick-effect Lining



# Studio Slimline Monaco Surround

Creating a stunning, contemporary centrepiece in your home, the Monaco surround for the Studio Slimline 1 is specifically designed for mounting the fire to a flat external wall and makes a statement wherever it is located. The Monaco's neat design means you can add the Slimline 1 fire to your living area without having to create a cavity in an existing wall, ensuring no additional building work is required to install the fire.

Thanks to its versatile design, the Monaco lets you tailor your fire surround to suit your tastes. With its modular construction, the surround can be assembled with the Slimline 1 fire positioned centrally or offset to the left or right. For added presence, you can increase the height either above or below the fire by adding an optional surround extension piece - letting you choose exactly how your Slimline Monaco will look in your home.

Offering further styling possibilities, the Monaco is supplied in a stunning unfinished concrete for minimalist elegance but can be easily painted with water based paints to suit your interior. Featuring a recessed storage plinth, the surround can also be visually enhanced with pre-cut logs for the natural feel of a woodburning fire.

## Key Features and Possible Configurations



1. Glass reinforced concrete surround
2. Choice of central or offset fire positioning
3. Black Granite top†
4. Integrated storage plinth
5. Shallow firebox depth of just 155mm
6. Balanced flue connection
7. Choice of linings
8. Choice of contemporary or realistic fuel effects
9. Convected and radiant heat system
10. Convected heat system outlet
11. Programmable Thermostatic remote control
12. Optional extension piece\*
13. Rear exit balanced flue termination kit included \*
14. External battery holder for ease of battery change\*
15. Optional mains adaptor\*

\* Not illustrated



Monaco with left aligned fire



Monaco with right aligned fire



Monaco with extension above centrally aligned fire



Monaco with extension below right aligned fire



Monaco with extension above left aligned fire

Δ Dimensions given are those overall visible upon installation. For more detailed technical information, including firebox dimensions and installation requirements, please see pages 64 - 65.

† Granite is a naturally occurring material and may exhibit subtle variations in colour and shade. The Black Granite top will become hot during use and is therefore unsuitable for placing objects on or using as a mantel.

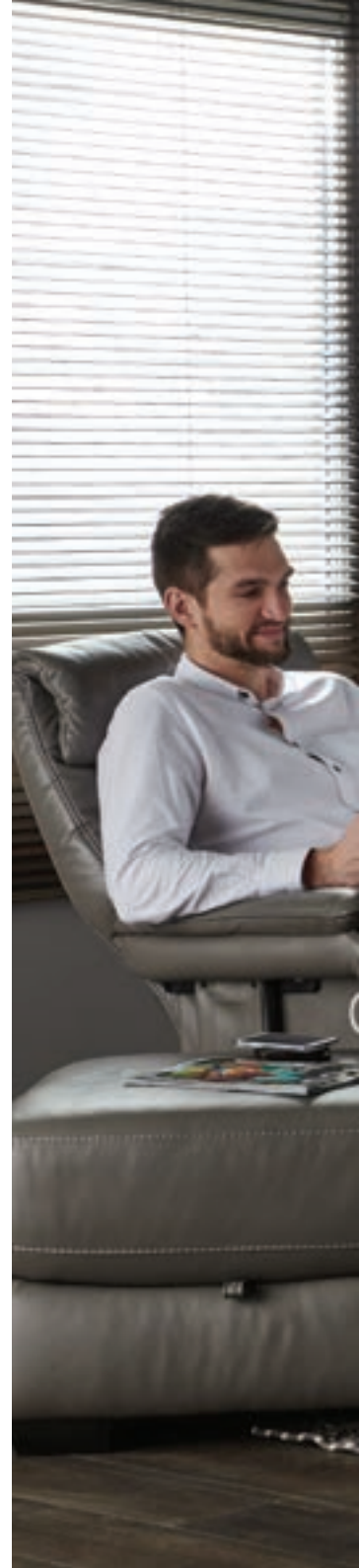





# Studio Duplex

For a truly awe-inspiring focal point in your home, the high efficiency, double-sided Duplex fire offers the ultimate solution to stylish dual space heating.



Studio 2 Duplex Balanced Flue, Glass frame with Log-effect fuel bed and Vermiculite lining

## A double-sided Studio fire

The Glass Fronted Studio 2 Duplex offers the unique installation possibility of locating the fire between two separate living areas, allowing the stunning flames and 7.9kW heat output to be appreciated from both sides. Featuring a hand finished, highly realistic, log-effect fuel bed and glowing ember bed, this innovative gas fire effortlessly creates warming, woodburning ambience at the touch of a button.

## Key Features

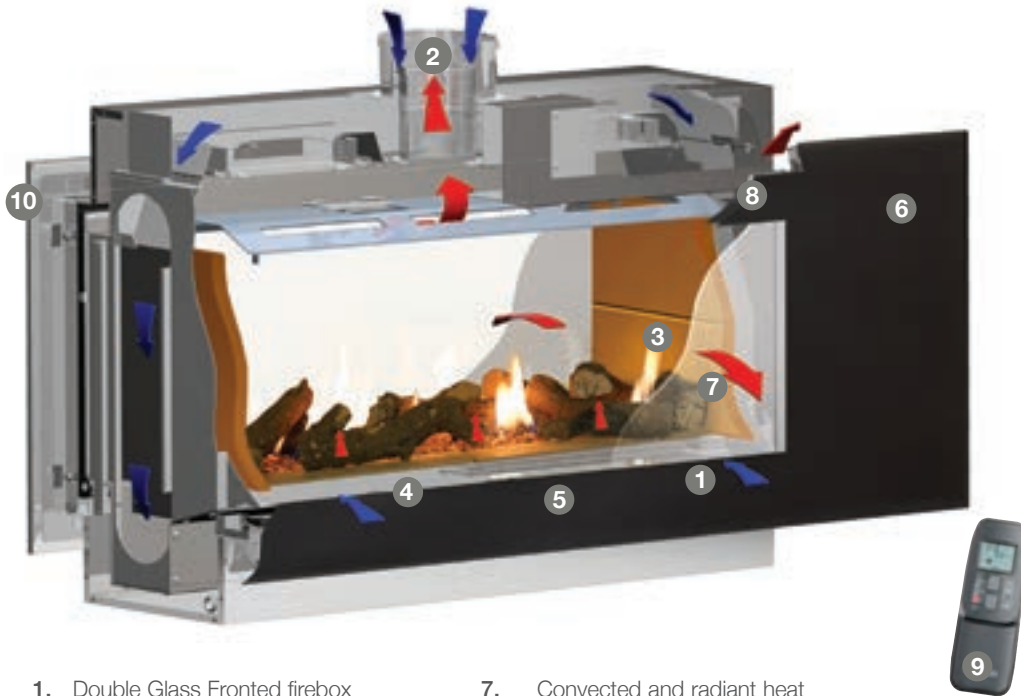

1. Double Glass Fronted firebox
2. Balanced Flue connection
3. Choice of linings
4. Realistic log-effect fire
5. Realistic Glowing ember feature
6. Wide choice of frame styles
7. Convected and radiant heat
8. Convected heat system outlet
9. Programmable Thermostatic remote control
10. Dual styling options
11. External battery holder for ease of battery change\*
12. Optional mains adaptor\*

\*Not Illustrated

## Lining Options



Vermiculite Lining



Black Reeded Lining

To further extend your options for personalisation, the Duplex offers a choice of linings, each providing a distinctly different look for your fire. The Vermiculite linings complement the hand-painted logs and boost the light appeal of the glowing fire. The Black Reeded linings however, provide a striking and contrasting backdrop that really serves to display the beautiful flames to their fullest potential.

## Duplex Frame Options

The Studio 2 Duplex has the benefit of dual styling possibilities, allowing you to select a different look for either side of the fire. Whether opting for a minimalist, hole-the-wall Edge installation or a glass or steel frame, there is a selection of styles that will attract the eye and enhance your two interior spaces. A selection of frame choices are shown overleaf, however a complete guide to all available options is shown on pages 16 - 17.



# Studio 2 Duplex



Studio 2 Duplex Balanced Flue, Profil frame in Anthracite with log-effect fuel bed and Vermiculite lining



Studio 2 Duplex Balanced Flue, Edge 'Cool Wall' with log-effect fuel bed and Black Reeded lining. See page 62 for further details on Cool Wall kits.

	Efficiency & Heat Output†			Chimney or Flue Options			Gas Type		Fuel Bed		Linings			Control	
	E%	ENERGY EFFICIENCY CLASS	kW HEAT OUTPUT	BRICK CHIMNEY	PRE-FABRICATED	BALANCED FLUE	NATURAL GAS	LPG GAS	LOGS	WHITE STONES	BRICK EFFECT	VERMICULITE	BLACK REEDED	BLACK GLASS	PROGRAMMABLE THERMOSTATIC REMOTE
Studio 2 Duplex Balanced Flue	92%	A	7.90kW	X	X	✓	✓	✓	✓	X	X	✓	✓	X	✓

† Efficiency and heat output figures are based upon the maximum achieved in the options available. For more detailed technical information, including firebox dimensions and installation requirements, see page 63.

**Frame Options**  
 For the complete selection of frames available with Studio fires please see pages 16 - 17.



Studio 2 Duplex Balanced Flue, Edge+ frame in Anthracite with log-effect fuel bed and Vermiculite lining

# Studio Freestanding

Studio Freestanding models present superb flames in an ultra-modern, landscape stove form that can be styled to suit your interior tastes.



Studio 2 Freestanding with White front and bench, Log-effect fuel bed and EchoFlame Black Glass lining



## Wide Range of Styling Options

The Studio Freestanding collection offers the stunning visuals and high efficiency heating of the inset Glass Fronted Studio fires in an arresting, stylishly contemporary stove form. Available with a choice of either black or white steel front, these designer stoves can also be configured with a matching plinth or bench.

In addition to exterior styling options, both Studio 1 & 2 Freestanding models have a choice of three, highly realistic, fuel beds including wood effect and Pebble & Stone options.

These advanced gas stoves are available in either conventional or balanced flue versions to suit your home and feature a Programmable Thermostatic handset for full control from the comfort of your armchair.

## Lining Options



EchoFlame Black Glass Lining



Vermiculite Lining



Black Reeded Lining

Heightening visuals, the highly reflective EchoFlame Black Glass lining enhances the depth of the firebox by mirroring the flames from multiple angles. Alternatively, additional Vermiculite or Black Reeded linings let you further customise your Studio Freestanding fire.



Studio 1 Freestanding with Black front and bench, Driftwood-effect fuel bed and EchoFlame Black Glass lining

# Studio 1 Freestanding



Studio 1 Freestanding with White front and bench, Log-effect fuel bed and Vermiculite lining



Studio 1 Freestanding with White front and plinth, Driftwood-effect fuel bed and Black Reeded lining

	Efficiency & Heat Output			Chimney or Flue Options			Gas Type		Fuel Bed			Linings			Control
	EFFICIENCY	EFFICIENCY CLASS	HEAT OUTPUT	BRICK CHIMNEY	PRE-FABRICATED	BALANCED FLUE	NATURAL GAS	LPG GAS	LOGS	DRIFTWOOD	PEBBLE & STONE	VERMICULITE	BLACK REEDED	BLACK GLASS	PROGRAMMABLE THERMOSTATIC REMOTE
Studio 1 Freestanding Conventional Flue	72%	E	4.60kW	✓	✓	✗	✓	✓	✓	✓	✓	✓	✓	✓	✓
Studio 1 Freestanding Balanced Flue	92%	A	5.30kW	✗	✗	✓	✓	✓	✓	✓	✓	✓	✓	✓	✓

† Efficiency and heat output figures are based upon the maximum achieved in the options available. For more detailed technical information, including firebox dimensions and installation requirements, see pages 66-67

\* Optional Linings

## Mounting Options

Studio Freestanding fires can be selected with a curved Plinth or Bench mount in either matching white or black finishes.





Studio 1 Freestanding with Black front and bench, Pebble & Stone fuel bed and EchoFlame Black Glass lining





Studio 2 Freestanding with White front and bench and Driftwood-effect fuel bed and EchoFlame Black Glass lining.

# Studio 2 Freestanding



Studio 2 Freestanding with Black front and plinth, Log-effect fuel bed and Vermiculite lining



Studio 2 Freestanding with Black front and bench, Pebble & Stone fuel bed and EchoFlame Black Glass lining

	Efficiency & Heat Output			Chimney or Flue Options			Gas Type		Fuel Bed			Linings			Control
	E% <sup>†</sup>	EFFICIENCY CLASS	kW	BRICK CHIMNEY	PRE-FABRICATED	BALANCED FLUE	NATURAL GAS	LPG GAS	LOGS	DRIFTWOOD	PEBBLE & STONE	BLACK GLASS	BLACK REEDED	VERMICULITE	PROGRAMMABLE THERMOSTATIC REMOTE
Studio 2 Glass Fronted Conventional Flue	81%	C	6.20kW	✓	✓	✗	✓	✓	✓	✓	✓	✓	✓*	✓*	✓
Studio 2 Glass Fronted Balanced Flue	92%	A	7.00kW	✗	✗	✓	✓	✓	✓	✓	✓	✓	✓*	✓*	✓

<sup>†</sup> Efficiency and heat output figures are based upon the maximum achieved in the options available. For more detailed technical information, including firebox dimensions and installation requirements, see pages 66 - 67.

\* Optional Linings

## Mounting Options

Studio Freestanding fires can be selected with a curved Plinth or Bench mount in either matching white or black finishes.

# Summary & Options

Diverse and versatile, the Studio fire range offers numerous possibilities from stylish frames and lining options to installations without a chimney. The table opposite shows the various options available for each Studio fire.





	Glass Fronted Studio Fires					Open Fronted Studio Fires			Glass Fronted Studio Slimline		Glass Fronted Studio 2 Duplex	Glass Fronted Studio Freestanding				
	Studio 1 CF	Studio 1 BF	Studio 2 CF	Studio 2 BF	Studio 3 BF	Studio 1 CF	Studio 2 CF	Studio 3 CF	Slimline 1 BF	Slimline 2 BF	Studio 2 Duplex BF	Freestanding 1 CF	Freestanding 1 BF	Freestanding 2 CF	Freestanding 2 BF	
<b>Choice of Fuel Bed:</b>																
Log-effect	✓	✓	✓	✓	✓	X	X	X	✓	✓	✓	✓	✓	✓	✓	✓
Driftwood-effect	✓	✓	✓	✓	✓	X	X	X	X	X	X	✓	✓	✓	✓	✓
Pebble & Stone	✓	✓	✓	✓	✓	X	X	X	X	X	X	✓	✓	✓	✓	✓
White Stone	X	X	X	X	X	✓	✓	✓	✓	✓	✓	X	X	X	X	X
Coloured Glass Beads	X	X	X	X	X	✓	✓	✓	✓	✓	✓	X	X	X	X	X
<b>Installation Type:</b>																
Hearth Mounted Installation	X	X	X	X	X	X	X	X	X	X	X	✓	✓	✓	✓	✓
Wall Installation	✓	✓	✓	✓	✓	✓	✓	✓	✓	✓	✓	X	X	X	X	X
Cavity Wall Specific Fire	X	X	X	X	X	X	X	X	✓	✓	✓	X	X	X	X	X
Double Sided Fire	X	X	X	X	X	X	X	X	X	X	✓	X	X	X	X	X
<b>Key Features:</b>																
Remote Control	✓	✓	✓	✓	✓	✓	✓	✓	✓	✓	✓	✓	✓	✓	✓	✓
Timer and Thermostat Programmable	✓	✓	✓	✓	✓	X	X	X	✓	✓	✓	✓	✓	✓	✓	✓
Glass Fronted High Efficiency	✓	✓	✓	✓	✓	X	X	X	✓	✓	✓	✓	✓	✓	✓	✓
Ambient Open Fire	X	X	X	X	X	✓	✓	✓	X	X	X	X	X	X	X	X
Natural Gas or LPG	✓	✓	✓	✓	✓	✓	✓	✓	✓	✓	✓	✓	✓	✓	✓	✓
Choice of Linings	✓	✓	✓	✓	✓	✓	✓	✓	✓	✓	✓	✓	✓	✓	✓	✓
Wide Selection of Frames	✓	✓	✓	✓	✓	✓	✓	✓	✓	✓	✓	X	X	X	X	X
Frameless 'Edge' Option	✓	✓	✓	✓	✓	✓	✓	✓	✓	✓	✓	X	X	X	X	X
Conventional Flue ODS safety device*	✓	n/a	✓	n/a	n/a	✓	✓	✓	n/a	n/a	n/a	✓	n/a	✓	n/a	n/a
Balanced Flue Firebox Relief Venting System <sup>Δ</sup>	n/a	✓	n/a	✓	✓	n/a	n/a	n/a	✓	✓	✓	n/a	✓	n/a	✓	✓
Additional air vent required	X	X	✓	X	X	X	✓	✓	X	X	X	X	X	✓	X	X
Conventional Flue	✓	X	✓	X	X	✓	✓	✓	X	X	X	✓	X	✓	✓	X
Balanced Flue	X	✓	X	✓	✓	X	X	X	✓	✓	✓	X	✓	X	✓	✓
Maximum Heat Output	4.60kW	5.30kW	6.20kW	7.00kW	8.40kW	1.72kW	2.30kW	3.40kW	4.25kW	5.00kW	7.90kW	4.60kW	5.30kW	6.20kW	7.00kW	
Efficiency Class	E	A	C	A	A	-	-	-	C	C	A	E	A	C	A	
Maximum Efficiency	72%	92%	81%	92%	92%	25%	25%	25%	82%	82%	92%	72%	92%	81%	92%	

\* ODS (Oxygen Depletion Sensor) - This Conventional Flue safety feature will shut off the gas supply to the burner in the event of a reduction to oxygen levels in the room. Δ All Gazco Balanced Flue fires have relief vents in the firebox ensuring compliance with EN 613:2001 for delayed ignition safety standards.

# Technical Information

The following pages provide the dimensional, heat input/output, efficiency and product code information you will need to choose your new Gazco fire. For more detailed specifications, please consult your Gazco retailer. Complete installation instructions may be downloaded from [www.gazco.com](http://www.gazco.com).

## Studio 1, 2 & 3 Open Fronted Fire Information

### OPEN FRONTED FIRES

Product Code	Description	Flue Type	Gas Type	Fuel Effect	Heat Input	Heat Output	Efficiency	Remote Control	Lining
⊗ 8700CHEC	Studio 1	Conventional	Nat. Gas	White Stones	6.90kW	1.72kW	25%	Standard	N/A
⊗ P8700CHEC	Studio 1	Conventional	LPG	White Stones	6.90kW	1.72kW	25%	Standard	N/A
8701CHEC	Studio 2	Conventional	Nat. Gas	White Stones	8.80kW	2.20kW	25%	Standard	N/A
P8701CHEC	Studio 2	Conventional	LPG	White Stones	9.30kW	2.30kW	25%	Standard	N/A
8702CHEC	Studio 3	Conventional	Nat. Gas	White Stones	13.20kW	3.30kW	25%	Standard	N/A
P8702CHEC	Studio 3	Conventional	LPG	White Stones	13.70kW	3.40kW	25%	Standard	N/A

### Additional Information (mm)

Dimension		Studio 1	Studio 2	Studio 3
A	Gather width	664	864	1254
B	Gather top	250	250	325
C	Gather taper	207	307	465
D	Base width	635	835	1225
E**	Box width	660	860	1250
F	Max. lintel width	130	130	130
G	Gather depth	187	187	187
H**	Box height	334	334	334
I*	Base height	133	133	133
J	Base depth	130	130	130
K	Base	182	182	182
L	Spigot height	50	50	50
M	Gather height	300	300	700
N	Total height	817	817	1217

\* adjustable feet can increase base height by up to 235 mm  
 \*\* If installed with one of the Studio frames, a 5mm space must be left around the front edge of the appliance.

### CHIMNEY TYPES

#### Studio 1

- **Class 1 brick built flue**
  - Can be fitted without the optional flue gather if the chimney is sound.
  - If the optional gather is used, then it must be connected to a 7" flexible flue liner suitable for gas.
- **Pre-fabricated 7" twin wall flue system suitable for gas**
  - Must be fitted with the optional flue gather.

#### Studio 2 and 3

- **Class 1 brick built flue**
  - Must be fitted with the flue gather.
- **Pre-fabricated 7" twin wall flue system suitable for gas**
  - Must be fitted with the flue gather.

### Appliance dimensions (mm)

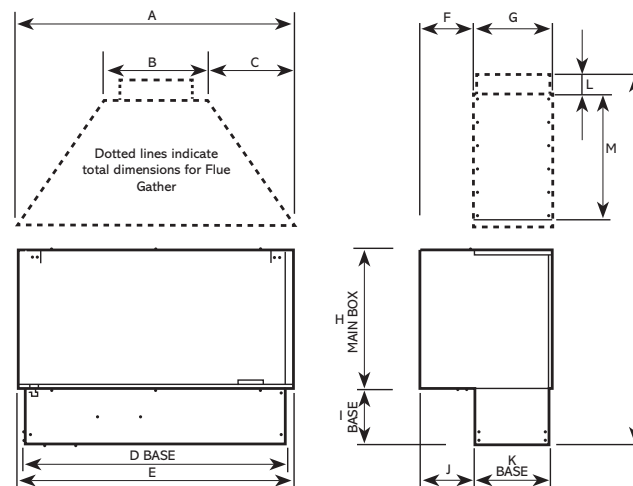

**Note:** it is possible to install the Studio 2 and 3 into a Class 1 brick flue. However, this type of installation should only be undertaken by chimney specialists. This is because it will require the front wall and structure of the chimney breast to be extensively cut away to allow enough width to fit the fire and also provide access to the top of the gather to allow either

- Connection of a 7" flexible flue liner suitable for gas
- Creation of a smooth transition between the top of the gather and the flue

Please note that carbon/soot deposits may be visible on inner back wall of the Open Fronted Studio fires due to variances in performance of flue systems, particularly in different prevailing weather conditions.



### Installing Televisions above Open Fronted Studio Fires

On a normal flue which is functioning correctly, Open Fronted Studios do not create a particularly hot environment on the wall above where they are installed. Therefore, it may be possible to install TV's above them, as long as the distance to the TV is a minimum of 450mm from the top of the fire and as long as it has been checked with the TV manufacturer's installation instructions with regard to installation and heat proximity. If in doubt please contact and check with your TV manufacturer.

**Glass Fronted Studio Fires** Gazco does not recommend installation of televisions above Glass Fronted Studio fires.

## Studio 1 Glass Fronted Gas Fire information

Supplied with Programmable Thermostatic remote control

- ▼ Choose your fire, fuel effect and lining set from the options below  
(framing options can be found on page 61)

### STEP 1 : FIRE CHOICE

		Heat Input	Heat Output	Efficiency	Efficiency Class
⊗ 123-007	Studio 1 Conventional Flue Natural Gas	6.30kW	4.10kW	72%	E
⊗ 123-603	Studio 1 Conventional Flue LPG	6.90kW	4.60kW	72%	E
⊗ 123-024	Studio 1 Balanced Flue Natural Gas	6.30kW	5.20kW	92%	A
⊗ 123-629	Studio 1 Balanced Flue LPG	6.30kW	5.30kW	92%	A

### STEP 2 : FUEL EFFECT

CE1839	Studio 1 Log Set
923-632	Studio 1 Pebble & Stone Set
923-019	Studio 1 Driftwood Set

### STEP 3 : LINING SETS

923-010	Studio 1 Conventional Flue - Vermiculite Lining Set
923-517	Studio 1 Conventional Flue - Black Reeded Lining Set
923-240	Studio 1 Conventional Flue - Black Glass Lining Set
923-433	Studio 1 Balanced Flue - Vermiculite Lining Set
923-607	Studio 1 Balanced Flue - Black Reeded Lining Set
923-282	Studio 1 Balanced Flue - Black Glass Lining Set

## Studio 2 Glass Fronted Gas Fire information

Supplied with Programmable Thermostatic remote control

- ▼ Choose your fire, fuel effect and lining set from the options below  
(framing options can be found on page 61)

### STEP 1 : FIRE CHOICE

		Heat Input	Heat Output	Efficiency	Efficiency Class
⊗ 123-012	Studio 2 Conventional Flue Natural Gas	8.50kW	6.20kW	81%	C
⊗ 123-611	Studio 2 Conventional Flue LPG	8.50kW	6.20kW	81%	C
⊗ 123-030	Studio 2 Balanced Flue Natural Gas	8.50kW	7.00kW	92%	A
⊗ 123-653	Studio 2 Balanced Flue LPG	8.00kW	6.80kW	92%	A

### STEP 2 : FUEL EFFECT

CE1840	Studio 2 Log Set
923-665	Studio 2 Pebble & Stone Set
923-037	Studio 2 Driftwood Set

### STEP 3 : LINING SETS

923-337	Studio 2 Conventional Flue - Vermiculite Lining Set
923-744	Studio 2 Conventional Flue - Black Reeded Lining Set
923-267	Studio 2 Conventional Flue - Black Glass Lining Set
923-938	Studio 2 Balanced Flue - Vermiculite Lining Set
923-476	Studio 2 Balanced Flue - Black Reeded Lining Set
923-294	Studio 2 Balanced Flue - Black Glass Lining Set



# Studio 3 Glass Fronted Gas Fire information

Supplied with Programmable Thermostatic remote control

▼ Choose your fire, fuel effect and lining set from the options below  
(framing options can be found on page 61)

## STEP 1 : FIRE CHOICE

		Heat Input	Heat Output	Efficiency	Efficiency Class
⊗ 123-043	Studio 3 Balanced Flue Natural Gas	10.10kW	8.40kW	92%	A
⊗ 123-666	Studio 3 Balanced Flue LPG	10.50kW	8.90kW	92%	A

## STEP 2 : FUEL EFFECT

CE1770	Studio 3 Log Set
923-686	Studio 3 Pebble & Stone Set
923-121	Studio 3 Driftwood Set

## STEP 3 : LINING SETS

923-795	Studio 3 Balanced flue - Vermiculite Lining Set
923-381	Studio 3 Balanced flue - Black Reeded Lining Set
923-365	Studio 3 Balanced flue - Black Glass Lining Set

## Additional Information

### Conventional Flue Installation

The conventionally flued Glass Fronted Studio has been designed with ease of installation in mind and can be installed two ways:

- 1) Direct connection to a 5" flue liner or 5" twin wall gas vent system
- 2) No additional fluing is needed when it is installed into an existing builders opening below a masonry chimney and sealed to the fireplace opening (assuming that the chimney is of sound construction).

### Glass Fronted, Conventional Flue Studio Dimensions (mm)

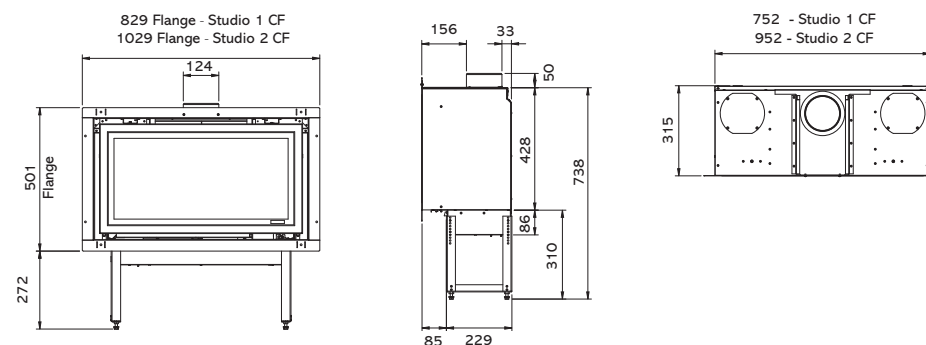

### Glass Fronted, Balanced Flue\* Studio Dimensions (mm)

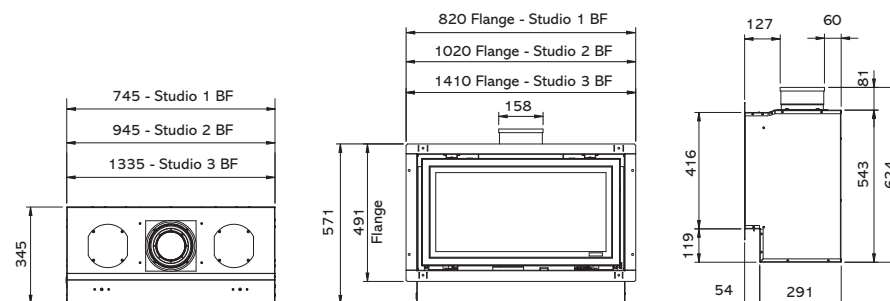

\* For more Balanced Flue information and options please refer to our Concentric Flue System brochure which can be viewed or downloaded online at [www.gazco.com](http://www.gazco.com)

# Studio 1, 2 & 3 Frame Information

Description	Frame Finish	Open Fronted Product Code	Frame Size (mm)			Glass Fronted CF Product Code	Frame Size (mm)			Glass Fronted BF Product Code	Frame Size (mm)		
			w	h	d		w	h	d		w	h	d
<b>STUDIO 1</b>													
Profil	Anthracite	<b>8710AN</b>	750	426	13	<b>8710CFAN01</b>	846	520	13	<b>8710BFAN01</b>	836	510	13
Profil	Polished Stainless Steel	<b>8710P</b>	750	426	13	<b>8710CFSS01</b>	846	520	13	<b>8710BFSS01</b>	836	510	13
Steel 2	Graphite	-	N/A	N/A	N/A	<b>923-883</b>	1264	528	27	<b>923-883</b>	1264	528	27
Expression	Graphite	-	N/A	N/A	N/A	<b>923-546</b>	950	624	40	<b>923-656</b>	940	614	40
Verve	Graphite	<b>923-437</b>	1264	528	54	<b>923-300</b>	1264	528	53	<b>923-300</b>	1264	528	53
Glass	Black Glass	<b>923-022</b>	1264	528	17	<b>923-628</b>	1264	528	29	<b>923-628</b>	1264	528	29
Edge+*	Black	-	N/A	N/A	N/A	<b>923-006</b>	788	464	43	<b>923-025</b>	778	454	43

## STUDIO 2

Profil	Anthracite	<b>8717AN</b>	950	426	13	<b>8717CFAN02</b>	1046	520	13	<b>8717BFAN02</b>	1036	510	13
Profil	Polished Stainless Steel	<b>8717P</b>	950	426	13	<b>8717CFSS02</b>	1046	520	13	<b>8717BFSS02</b>	1036	510	13
Steel 2	Graphite	-	N/A	N/A	N/A	<b>923-556</b>	1500	528	27	<b>923-556</b>	1500	528	27
Expression	Graphite	-	N/A	N/A	N/A	<b>923-574</b>	1150	624	40	<b>923-709</b>	1140	614	40
Verve	Graphite	-	N/A	N/A	N/A	<b>923-514</b>	1500	528	53	<b>923-514</b>	1500	528	53
Glass	Black Glass	<b>923-135</b>	1500	528	17	<b>923-535</b>	1500	528	29	<b>923-535</b>	1500	528	29
Edge+*	Black	-	N/A	N/A	N/A	<b>923-017</b>	988	464	43	<b>923-028</b>	978	454	43

## STUDIO 3

Profil	Anthracite	<b>8720AN</b>	1340	426	13	-	N/A	N/A	N/A	<b>8720BFAN03</b>	1426	510	13
Profil	Polished Stainless Steel	<b>8720P</b>	1340	426	13	-	N/A	N/A	N/A	<b>8720BFSS03</b>	1426	510	13
Expression	Graphite	-	N/A	N/A	N/A	-	N/A	N/A	N/A	<b>923-753</b>	1530	614	40
Verve	Graphite	<b>923-355</b>	1990	528	54	-	N/A	N/A	N/A	-	N/A	N/A	N/A
Glass	Black Glass	-	N/A	N/A	N/A	-	N/A	N/A	N/A	-	N/A	N/A	N/A
Edge+*	Black	-	N/A	N/A	N/A	-	N/A	N/A	N/A	<b>923-040</b>	1368	454	43

\*When choosing an Edge+ frame an Edge kit is also required for installation.

# Studio 1, 2 & 3 Options & Accessories

## OPEN FRONTED STUDIO FIRES

Product Code	Description
<b>STUDIO 1</b>	
<b>8714GBK</b>	Black Granite linings
<b>8713</b>	Flue gather*
<b>STUDIO 2</b>	
<b>8715GBK</b>	Black Granite linings
<b>STUDIO 3</b>	
<b>8716GBK</b>	Black Granite linings

\* Flue gather automatically included with Open Fronted Studio 2 & 3 Fires.

## UPGRADEABLE GLASS BEAD FUEL EFFECTS<sup>◇</sup>

### STUDIO 1 - OPEN FRONTED

<b>923-797</b>	Clear Glass fuel effect upgrade
<b>923-735</b>	Black Glass fuel effect upgrade

### STUDIO 2 - OPEN FRONTED

<b>923-751</b>	Clear Glass fuel effect upgrade
<b>923-760</b>	Black Glass fuel effect upgrade

### STUDIO 3 - OPEN FRONTED

<b>923-718</b>	Clear Glass fuel effect upgrade
<b>923-706</b>	Black Glass fuel effect upgrade

Black Glass Beads



Clear Glass Beads



◇ The Glass Bead fuel options are available as a retro-fit solution to replace and enliven any White Stone Studio Balanced Flue fires if desired.

† For more Balanced Flue information and options please refer to our Concentric Flue System brochure which can be viewed or downloaded online at [www.gazco.com](http://www.gazco.com)

## GLASS FRONTED STUDIO FIRES

Product Code	Description
<b>8572</b>	Warm air ducting kit (2 outlets)
<b>8524</b>	Balanced flue kit - vertical †
<b>999-620</b>	Remote system mains adaptor
<b>STUDIO 1</b>	
<b>8727CFEK01</b>	Edge fitting kit for conventional flue
<b>8727BFEK01</b>	Edge fitting kit for balanced flue †
<b>8727CFCW01</b>	Cool Wall fitting kit for conventional flue
<b>8727BFCW01</b>	Cool Wall fitting kit for balanced flue †
<b>8534</b>	Balanced flue kit - up and out †
<b>923-517</b>	Black Reeded lining set for conventional flue
<b>923-607</b>	Black Reeded lining set for balanced flue
<b>923-010</b>	Vermiculite lining set for conventional flue
<b>923-433</b>	Vermiculite lining set for balanced flue
<b>923-240</b>	Black Glass lining set for conventional flue
<b>923-282</b>	Black Glass lining set for balanced flue

### STUDIO 2

<b>8727CFEK02</b>	Edge fitting kit for conventional flue
<b>8727BFEK02</b>	Edge fitting kit for balanced flue †
<b>8727CFCW02</b>	Cool Wall fitting kit for conventional flue
<b>8727BFCW02</b>	Cool Wall fitting kit for balanced flue †
<b>8509</b>	Balanced flue kit - up and out †
<b>923-744</b>	Black Reeded lining set for conventional flue
<b>923-476</b>	Black Reeded lining set for balanced flue
<b>923-337</b>	Vermiculite lining set for conventional flue
<b>923-938</b>	Vermiculite lining set for balanced flue
<b>923-267</b>	Black Glass lining set for conventional flue
<b>923-294</b>	Black Glass lining set for balanced flue

### STUDIO 3

<b>8727BFEK03</b>	Edge fitting kit for balanced flue †
<b>8727BFCW03</b>	Cool Wall fitting kit for balanced flue †
<b>8567</b>	Balanced flue kit - up and out †
<b>923-381</b>	Black Reeded lining set for balanced flue
<b>923-795</b>	Vermiculite lining set for balanced flue
<b>923-365</b>	Black Glass lining set for balanced flue

# Studio Edge & Cool Wall Kits

Available for Glass Fronted Studio fires

## Edge Kit

This kit is screw-mounted to the front flange of the outer firebox. The L-shaped attachments can either provide a 20mm return against which high temperature plasterboard/screed can be butted up for the 'clean edge' look or, if the firebox flange is on the outside of a brick or studwork wall, allow ceramic or stone tiles to be fixed with a similar look. The Edge Kit is finished in black to complement the Studio and is perfect for installations on tiled walls or using stone slips. For a seamless Edge installation on a plastered wall it we suggest using the below 'Cool Wall' kit.

## Cool Wall Kit

Again, screw-mounted to the front flange of the outer firebox, the 60mm deep U-shaped attachments of the Cool Wall kit are designed primarily for studwork false chimney breasts. The additional depth allows some of the heat to be vented up into the void above the firebox and then re-enter the room at a higher level. The effect is to produce a cooler wall immediately above the appliance than would otherwise be the case. The Cool Wall Kit is left unfinished so that it can be painted to match the front face of your fireplace.

### Edge Kit

Installation method for:

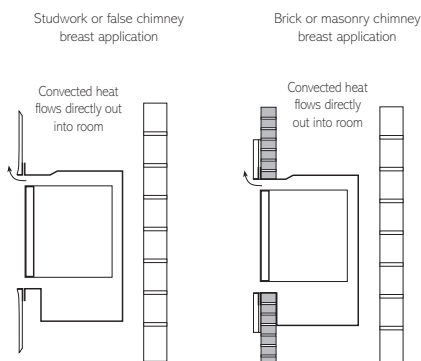

When using the Edge Kit the fire is recessed by 20mm from the finished wall surface and the kit is finished in black to complement the Studio.

**NB:** When using the Edge Kit, heat resistant board and high temperature finishing plaster must be used. Please refer to installation instructions for full details.

### Cool Wall Kit

Installation method for:

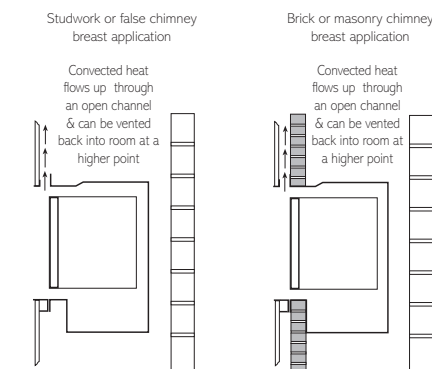

When using the Cool Wall Kit the fire is recessed by 60mm from the finished wall surface and the kit is left unfinished so that it can be painted to match your decor.

**NB:** Full installation information, including the requirement for the use of non-combustible materials, can be downloaded from [www.gazco.com](http://www.gazco.com)



# Studio 2 Duplex Fires

## FIRE INFORMATION

Product Code	Flue Type	Gas Type	Fuel Effect	Heat Input	Heat Output	Efficiency	Efficiency Class	Lining
⊗ 123-319	Balanced flue	Nat. Gas	Logs	9.6kW	7.9kW	92%	A	Vermiculite
⊗ 123-421	Balanced flue	LPG	Logs	9.3kW	7.9kW	92%	A	Vermiculite
⊗ 123-329	Balanced flue	Nat. Gas	Logs	9.6kW	7.9kW	92%	A	Black Reeded
⊗ 123-500	Balanced flue	LPG	Logs	9.3kW	7.9kW	92%	A	Black Reeded

## STUDIO 2 DUPLEX DIMENSIONS (mm)

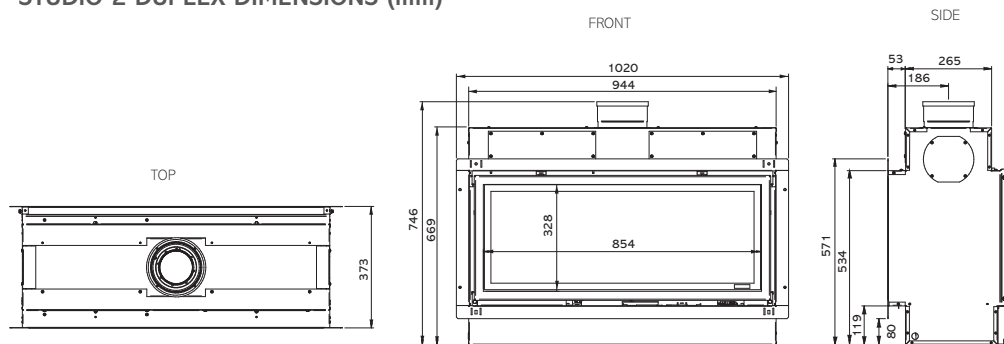

## FRAME INFORMATION

Description	Frame Finish	Product Code	Frame Size (mm)		
			w	h	d
Profil	Anthracite	8717BFAN02	1036	510	13
Profil	Polished Stainless Steel	8717BFSS02	1036	510	13
Steel 2	Graphite	923-556	1500	528	30
Expression	Graphite	923-709	1140	614	40
Verve	Graphite	923-514	1500	528	56
Glass	Black Glass	923-535	1500	528	33.5
Edge+	Black	923-028	978	454	43

## STUDIO 2 DUPLEX OPTIONS

Product Code	Description
8727BFEK02	Edge fitting kit for BF †
8727BFCW02	Cool Wall fitting kit for BF †
8572	Warm air ducting kit (2 outlets)
923-538	Duplex - Vermiculite Lining Set
923-696	Duplex - Black Reed Lining Set
8567	Balanced flue kit - up and out †
8524	Balanced flue kit - vertical †
999-201	Horizontal Exit terminal guard (required for below 2m) †
999-620	Remote system mains adaptor

† For more Balanced Flue information and options please refer to our Concentric Flue System brochure which can be viewed or downloaded online at [www.gazco.com](http://www.gazco.com)

The above information is to assist you in your choice of a suitable Gazco fire. This is not intended to be all the information required to install your fire. This can be obtained from your local Gazco retailer or you can download the full installation instructions from the Gazco website at [www.gazco.com](http://www.gazco.com)



Studio 2 Duplex Balanced Flue, Edge+ frame in Anthracite with log-effect fuel bed and Vermiculite lining

# Studio 1 & 2 Slimline Fires

## STUDIO 1 SLIMLINE FIRE INFORMATION

Product Code	Description	Flue Type	Gas Type	Fuel Effect	Heat Input	Heat Output	Efficiency	Efficiency Class	Lining
⊗ 123-022	Studio 1 Slimline	Balanced	Nat. Gas	Logs	5.2kW	3.8kW	82%	C	Vermiculite
⊗ 123-691	Studio 1 Slimline	Balanced	LPG	Logs	5.1kW	3.8kW	82%	C	Vermiculite
⊗ 123-126	Studio 1 Slimline	Balanced	Nat. Gas	White Stones	5.2kW	3.8kW	82%	C	Vermiculite
⊗ 123-756	Studio 1 Slimline	Balanced	LPG	White Stones	5.1kW	3.8kW	82%	C	Vermiculite
⊗ 123-169	Studio 1 Slimline	Balanced	Nat. Gas	Logs	5.2kW	3.8kW	82%	C	Black Reeded
⊗ 123-504	Studio 1 Slimline	Balanced	LPG	Logs	5.1kW	3.8kW	82%	C	Black Reeded
⊗ 123-375	Studio 1 Slimline	Balanced	Nat. Gas	White Stones	5.2kW	3.8kW	82%	C	Black Reeded
⊗ 123-460	Studio 1 Slimline	Balanced	LPG	White Stones	5.1kW	3.8kW	82%	C	Black Reeded
⊗ 123-353	Studio 1 Slimline	Balanced	Nat. Gas	Logs	5.2kW	3.8kW	82%	C	Brick-effect
⊗ 123-432	Studio 1 Slimline	Balanced	LPG	Logs	5.1kW	3.8kW	82%	C	Brick-effect
⊗ 123-266	Studio 1 Slimline	Balanced	Nat. Gas	White Stones	5.2kW	3.8kW	82%	C	Brick-effect
⊗ 123-497	Studio 1 Slimline	Balanced	LPG	White Stones	5.1kW	3.8kW	82%	C	Brick-effect
⊗ 123-143	Studio 1 Slimline	Balanced	Nat. Gas	Logs	5.2kW	3.8kW	82%	C	Black Glass
⊗ 123-623	Studio 1 Slimline	Balanced	LPG	Logs	5.1kW	3.8kW	82%	C	Black Glass
⊗ 123-223	Studio 1 Slimline	Balanced	Nat. Gas	White Stones	5.2kW	3.8kW	82%	C	Black Glass
⊗ 123-634	Studio 1 Slimline	Balanced	LPG	White Stones	5.1kW	3.8kW	82%	C	Black Glass

## STUDIO 2 SLIMLINE FIRE INFORMATION

Product Code	Description	Flue Type	Gas Type	Fuel Effect	Heat Input	Heat Output	Efficiency	Remote Control	Lining
⊗ 123-344	Studio 2 Slimline	Balanced	Nat. Gas	Logs	6.1kW	4.5kW	82%	C	Vermiculite
⊗ 123-590	Studio 2 Slimline	Balanced	LPG	Logs	6.6kW	5.0kW	82%	C	Vermiculite
⊗ 123-081	Studio 2 Slimline	Balanced	Nat. Gas	White Stones	6.1kW	4.5kW	82%	C	Vermiculite
⊗ 123-599	Studio 2 Slimline	Balanced	LPG	White Stones	6.6kW	5.0kW	82%	C	Vermiculite
⊗ 123-321	Studio 2 Slimline	Balanced	Nat. Gas	Logs	6.1kW	4.5kW	82%	C	Black Reeded
⊗ 123-553	Studio 2 Slimline	Balanced	LPG	Logs	6.6kW	5.0kW	82%	C	Black Reeded
⊗ 123-027	Studio 2 Slimline	Balanced	Nat. Gas	White Stones	6.1kW	4.5kW	82%	C	Black Reeded
⊗ 123-583	Studio 2 Slimline	Balanced	LPG	White Stones	6.6kW	5.0kW	82%	C	Black Reeded
⊗ 123-396	Studio 2 Slimline	Balanced	Nat. Gas	Logs	6.1kW	4.5kW	82%	C	Brick-effect
⊗ 123-608	Studio 2 Slimline	Balanced	LPG	Logs	6.6kW	5.0kW	82%	C	Brick-effect
⊗ 123-110	Studio 2 Slimline	Balanced	Nat. Gas	White Stones	6.1kW	4.5kW	82%	C	Brick-effect
⊗ 123-615	Studio 2 Slimline	Balanced	LPG	White Stones	6.6kW	5.0kW	82%	C	Brick-effect
⊗ 123-102	Studio 2 Slimline	Balanced	Nat. Gas	Logs	6.1kW	4.5kW	82%	C	Black Glass
⊗ 123-545	Studio 2 Slimline	Balanced	LPG	Logs	6.6kW	5.0kW	82%	C	Black Glass
⊗ 123-117	Studio 2 Slimline	Balanced	Nat. Gas	White Stones	6.1kW	4.5kW	82%	C	Black Glass
⊗ 123-571	Studio 2 Slimline	Balanced	LPG	White Stones	6.6kW	5.0kW	82%	C	Black Glass

## STUDIO 1 SLIMLINE FRAME INFORMATION

Frame	Frame Finish	Product Code	Frame Size (mm)		
			w	h	d
Profil	Anthracite	8710BFAN01	836	510	13
Profil	Polished Stainless	8710BFSS01	836	510	13
Steel 2	Graphite	923-883	1264	528	30
Expression	Graphite	923-656	940	614	40
Verve	Graphite	923-300	1264	528	56
Glass	Black Glass	923-628	1264	528	33.5
ZC Steel**	Graphite	923-715	940	615	27
ZC Glass**	Black Glass	923-757	940	615	31
ZC Glass**	White Glass	923-950	940	615	31

## STUDIO 1 SLIMLINE MONACO INFORMATION

Monaco**	Concrete	923-089	1220	1379	225
Ext. Piece	Concrete	923-114	1220	300	225

## STUDIO 2 SLIMLINE FRAME INFORMATION

Frame	Frame Finish	Product Code	Frame Size (mm)		
			w	h	d
Profil	Anthracite	8717BFAN02	1036	510	12.5
Profil	Polished Stainless	8717BFSS02	1036	510	12.5
Steel 2	Graphite	923-556	1500	528	27
Expression	Graphite	923-709	1140	614	40
Verve	Graphite	923-514	1500	528	53
Glass	Black Glass	923-535	1500	528	29
ZC Steel**	Graphite	923-720	1140	615	27
ZC Glass**	Black Glass	923-772	1140	615	31
ZC Glass**	White Glass	923-987	1140	615	31

◇ Available as a retro-fit solution to replace and enliven any White Stone Studio fires.

‡ Available as an upgrade to Studio fires with a log effect fuel bed

\*\* Please see page 65 for further dimensions. ZC Frames come complete with the Zero Clearance Box.

## STUDIO 1 SLIMLINE OPTIONS

Product Code	Description
8727BFEK01	Edge fitting kit for BF †
8727BFCW01	Cool Wall fitting kit for BF †
923-733	Vermiculite Lining Set ‡
923-826	Black Reeded Lining Set ‡
923-765	Brick-effect Lining Set ‡
923-124	Black Glass Lining Set ‡
923-774	Clear Glass fuel effect upgrade ◇
923-788	Black Glass fuel effect upgrade ◇
999-620	Remote system mains adaptor

## STUDIO 2 SLIMLINE OPTIONS

Product Code	Description
8727BFEK02	Edge fitting kit for BF †
8727BFCW02	Cool Wall fitting kit for BF †
923-257	Vermiculite Lining Set ‡
923-226	Black Reeded Lining Set ‡
923-273	Brick-effect Lining Set ‡
923-314	Black Glass Lining Set ‡
923-797	Clear Glass fuel effect upgrade ◇
923-735	Black Glass fuel effect upgrade ◇
999-620	Remote system mains adaptor

# Studio 1 & 2 Slimline Fires (continued)

## STUDIO SLIMLINE DIMENSIONS (mm)

Dimensions are the same for both models, except where specified

TOP VIEW

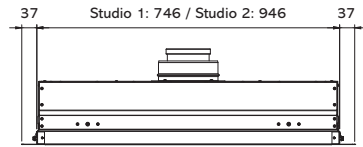

FRONT AND SIDE VIEW

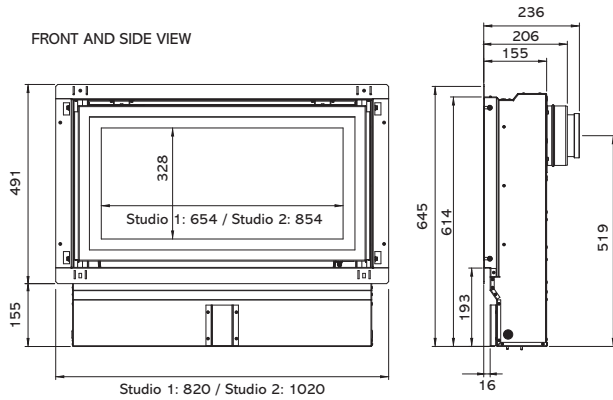

The Studio 1 and 2 Slimline comes complete with a specific rear exit balanced flue termination kit (8526) included.  
395 x 200 x 200 mm (H x W x D) Guard supplied. Cut to length as required on site.

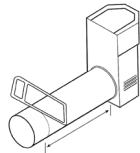

## ZERO CLEARANCE FRAME DIMENSIONS (mm)

Dimensions are the same for both models, except where specified

ZERO CLEARANCE BOX DIMENSIONS

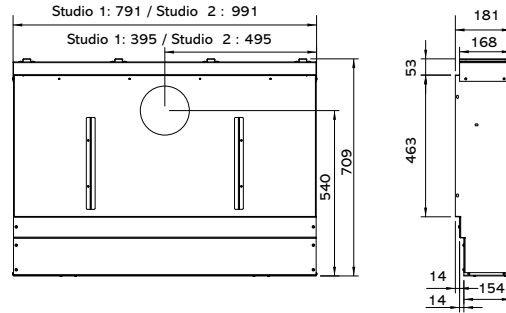

FRAME DIMENSIONS

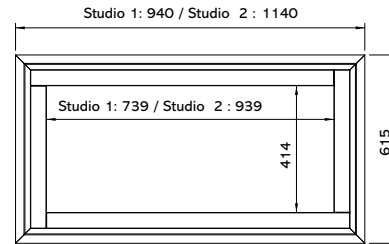

ZC GLASS 31  
ZC STEEL 27

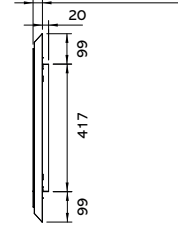

COMPLETE PRODUCT DIMENSIONS (FRAME & ZERO CLEARANCE BOX)

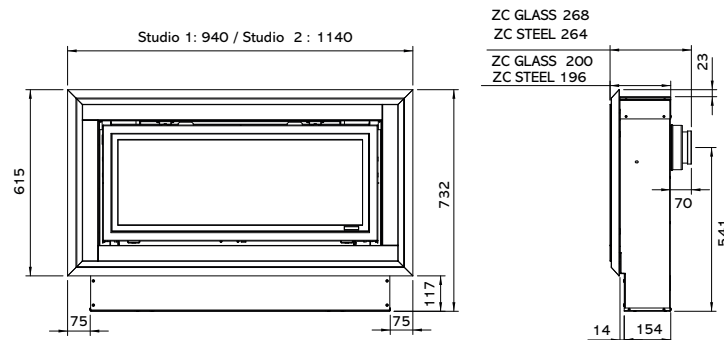

ZC GLASS 268  
ZC STEEL 264

ZC GLASS 200  
ZC STEEL 196

## MONACO SURROUND DIMENSIONS (mm)

CENTRALLY ALIGNED FIRE

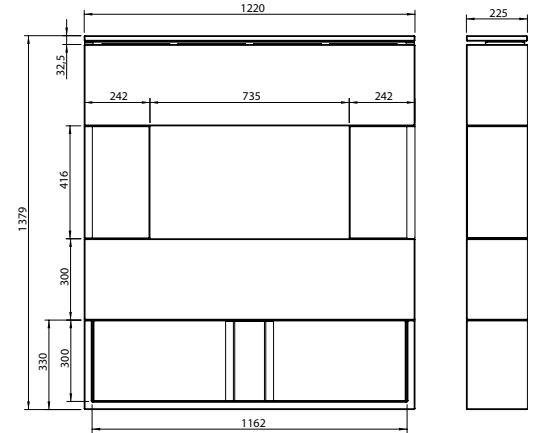

OFFSET FIRE

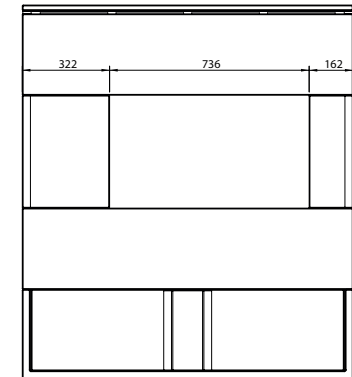

EXTENSION PIECE

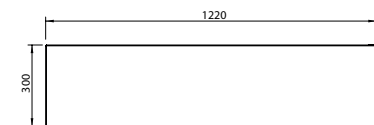



# Studio 1 Freestanding Supplied with Programmable Thermostatic Remote

## STUDIO 1 FREESTANDING FIRE INFORMATION

Product Code	Front Finish	Flue Type	Gas Type	Fuel Effect	Heat Input	Heat Output	Efficiency	Efficiency Class	Lining
<b>LOG-EFFECT FUEL BED, CONVENTIONAL FLUE</b>									
⊗ 508-147	Black	Conventional Flue	Nat. Gas	Logs	6.30kW	4.10kW	72%	E	Black Glass
⊗ 508-589	Black	Conventional Flue	LPG	Logs	6.90kW	4.60kW	72%	E	Black Glass
⊗ 508-199	White	Conventional Flue	Nat. Gas	Logs	6.30kW	4.10kW	72%	E	Black Glass
⊗ 508-606	White	Conventional Flue	LPG	Logs	6.90kW	4.60kW	72%	E	Black Glass

## PEBBLE & STONE FUEL BED, CONVENTIONAL FLUE

⊗ 508-077	Black	Conventional Flue	Nat. Gas	Pebble & Stone	6.30kW	4.10kW	72%	E	Black Glass
⊗ 508-517	Black	Conventional Flue	LPG	Pebble & Stone	6.90kW	4.60kW	72%	E	Black Glass
⊗ 508-366	White	Conventional Flue	Nat. Gas	Pebble & Stone	6.30kW	4.10kW	72%	E	Black Glass
⊗ 508-615	White	Conventional Flue	LPG	Pebble & Stone	6.90kW	4.60kW	72%	E	Black Glass

## DRIFTWOOD-EFFECT FUEL BED, CONVENTIONAL FLUE

⊗ 508-045	Black	Conventional Flue	Nat. Gas	Driftwood	6.30kW	4.10kW	72%	E	Black Glass
⊗ 508-440	Black	Conventional Flue	LPG	Driftwood	6.90kW	4.60kW	72%	E	Black Glass
⊗ 508-066	White	Conventional Flue	Nat. Gas	Driftwood	6.30kW	4.10kW	72%	E	Black Glass
⊗ 508-479	White	Conventional Flue	LPG	Driftwood	6.90kW	4.60kW	72%	E	Black Glass

## LOG-EFFECT FUEL BED, BALANCED FLUE

⊗ 508-248	Black	Balanced Flue	Nat. Gas	Logs	6.30kW	5.20kW	92%	A	Black Glass
⊗ 508-597	Black	Balanced Flue	LPG	Logs	6.30kW	5.30kW	92%	A	Black Glass
⊗ 508-151	White	Balanced Flue	Nat. Gas	Logs	6.30kW	5.20kW	92%	A	Black Glass
⊗ 508-488	White	Balanced Flue	LPG	Logs	6.30kW	5.30kW	92%	A	Black Glass

## PEBBLE & STONE FUEL BED, BALANCED FLUE

⊗ 508-396	Black	Balanced Flue	Nat. Gas	Pebble & Stone	6.30kW	5.20kW	92%	A	Black Glass
⊗ 508-699	Black	Balanced Flue	LPG	Pebble & Stone	6.30kW	5.30kW	92%	A	Black Glass
⊗ 508-175	White	Balanced Flue	Nat. Gas	Pebble & Stone	6.30kW	5.20kW	92%	A	Black Glass
⊗ 508-510	White	Balanced Flue	LPG	Pebble & Stone	6.30kW	5.30kW	92%	A	Black Glass

## DRIFTWOOD FUEL BED, BALANCED FLUE

⊗ 508-057	Black	Balanced Flue	Nat. Gas	Driftwood	6.30kW	5.20kW	92%	A	Black Glass
⊗ 508-465	Black	Balanced Flue	LPG	Driftwood	6.30kW	5.30kW	92%	A	Black Glass
⊗ 508-117	White	Balanced Flue	Nat. Gas	Driftwood	6.30kW	5.20kW	92%	A	Black Glass
⊗ 508-502	White	Balanced Flue	LPG	Driftwood	6.30kW	5.30kW	92%	A	Black Glass

## STUDIO 1 FREESTANDING PLINTH & BENCH MOUNTING CHOICE (REQUIRED)

999-022	Studio 1 Freestanding Plinth - Black
999-035	Studio 1 Freestanding Plinth - White
999-101	Studio 1 Freestanding Bench - Black
999-114	Studio 1 Freestanding Bench - White

## ACCESSORIES

923-517	Studio 1 Conventional Flue - Black Reeded Lining Set
923-010	Studio 1 Conventional Flue - Vermiculite Lining Set
923-240	Studio 1 Conventional Flue - Black Glass Lining Set
923-607	Studio 1 Balanced Flue - Black Reeded Lining Set
923-433	Studio 1 Balanced Flue - Vermiculite Lining Set
923-282	Studio 1 Balanced Flue - Black Glass Lining Set
999-620	Remote System Mains Adaptor

## STUDIO FREESTANDING GAS DIMENSIONS (mm)

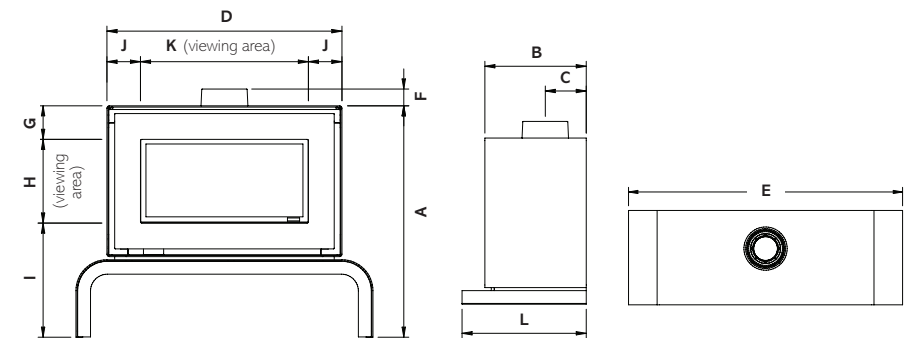

All sizes in mm	A	B	C	D	E	F	G	H	I	J	K	L
<b>Studio 1 Freestanding Bench</b>	896	396	CF: 148 BF: 160	910	1150	CF: 43 BF: 65	130	324	442	130	650	-
<b>Studio 1 Freestanding Plinth</b>	649	396	CF: 148 BF: 160	910	1105	CF: 43 BF: 65	130	324	195	130	650	485

# Studio 2 Freestanding Supplied with Programmable Thermostatic Remote

## STUDIO 2 FREESTANDING FIRE INFORMATION

Product Code	Front Finish	Flue Type	Gas Type	Fuel Effect	Heat Input	Heat Output	Efficiency	Efficiency Class	Lining
<b>LOG-EFFECT FUEL BED, CONVENTIONAL FLUE</b>									
508-094	Black	Conventional Flue	Nat. Gas	Logs	8.50kW	6.90kW	81%	C	Black Glass
508-426	Black	Conventional Flue	LPG	Logs	8.50kW	6.90kW	81%	C	Black Glass
508-187	White	Conventional Flue	Nat. Gas	Logs	8.50kW	6.90kW	81%	C	Black Glass
508-418	White	Conventional Flue	LPG	Logs	8.50kW	6.90kW	81%	C	Black Glass

## PEBBLE & STONE FUEL BED, CONVENTIONAL FLUE

508-207	Black	Conventional Flue	Nat. Gas	Pebble & Stone	8.50kW	6.90kW	81%	C	Black Glass
508-651	Black	Conventional Flue	LPG	Pebble & Stone	8.50kW	6.90kW	81%	C	Black Glass
508-282	White	Conventional Flue	Nat. Gas	Pebble & Stone	8.50kW	6.90kW	81%	C	Black Glass
508-750	White	Conventional Flue	LPG	Pebble & Stone	8.50kW	6.90kW	81%	C	Black Glass

## DRIFTWOOD-EFFECT FUEL BED, CONVENTIONAL FLUE

508-201	Black	Conventional Flue	Nat. Gas	Driftwood	8.50kW	6.90kW	81%	C	Black Glass
508-498	Black	Conventional Flue	LPG	Driftwood	8.50kW	6.90kW	81%	C	Black Glass
508-303	White	Conventional Flue	Nat. Gas	Driftwood	8.50kW	6.90kW	81%	C	Black Glass
508-581	White	Conventional Flue	LPG	Driftwood	8.50kW	6.90kW	81%	C	Black Glass

## LOG-EFFECT FUEL BED, BALANCED FLUE

508-027	Black	Balanced Flue	Nat. Gas	Logs	8.50kW	7.00kW	92%	A	Black Glass
508-444	Black	Balanced Flue	LPG	Logs	8.00kW	6.80kW	92%	A	Black Glass
508-102	White	Balanced Flue	Nat. Gas	Logs	8.50kW	7.00kW	92%	A	Black Glass
508-640	White	Balanced Flue	LPG	Logs	8.00kW	6.80kW	92%	A	Black Glass

## PEBBLE & STONE FUEL BED, BALANCED FLUE

508-033	Black	Balanced Flue	Nat. Gas	Pebble & Stone	8.50kW	7.00kW	92%	A	Black Glass
508-527	Black	Balanced Flue	LPG	Pebble & Stone	8.00kW	6.80kW	92%	A	Black Glass
508-322	White	Balanced Flue	Nat. Gas	Pebble & Stone	8.50kW	7.00kW	92%	A	Black Glass
508-508	White	Balanced Flue	LPG	Pebble & Stone	8.00kW	6.80kW	92%	A	Black Glass

## DRIFTWOOD-EFFECT FUEL BED, BALANCED FLUE

508-171	Black	Balanced Flue	Nat. Gas	Driftwood	8.50kW	7.00kW	92%	A	Black Glass
508-562	Black	Balanced Flue	LPG	Driftwood	8.00kW	6.80kW	92%	A	Black Glass
508-382	White	Balanced Flue	Nat. Gas	Driftwood	8.50kW	7.00kW	92%	A	Black Glass
508-655	White	Balanced Flue	LPG	Driftwood	8.00kW	6.80kW	92%	A	Black Glass

## STUDIO 2 FREESTANDING PLINTH & BENCH MOUNTING CHOICE (REQUIRED)

999-048	Studio 2 Freestanding Plinth - Black
999-087	Studio 2 Freestanding Plinth - White
999-127	Studio 2 Freestanding Bench - Black
999-166	Studio 2 Freestanding Bench - White

## ACCESSORIES

923-744	Studio 2 Conventional Flue - Black Reeded Lining Set
923-337	Studio 2 Conventional Flue - Vermiculite Lining Set
923-267	Studio 2 Conventional Flue - Black Glass Lining Set
923-476	Studio 2 Balanced Flue - Black Reeded Lining Set
923-938	Studio 2 Balanced Flue - Vermiculite Lining Set
923-294	Studio 2 Balanced Flue - Black Glass Lining Set
999-620	Remote System Mains Adaptor

## STUDIO FREESTANDING GAS DIMENSIONS (mm)

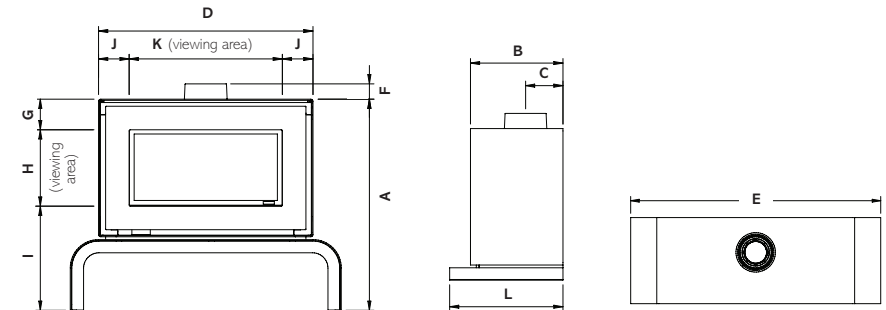

All sizes in mm	A	B	C	D	E	F	G	H	I	J	K	L
<b>Studio 2 Freestanding Bench</b>	896	396	CF: 148 BF: 160	1110	1350	CF: 43 BF: 65	130	324	442	130	850	-
<b>Studio 2 Freestanding Plinth</b>	649	396	CF: 148 BF: 160	1110	1305	CF: 43 BF: 65	130	324	195	130	850	485

# Your Home & Flue Requirements...

## Conventional Flue

Conventional flue systems are for Gazco's Open Fronted and some Glass Fronted gas fires. They are easily recognisable as either a conventional brick or stone chimney, or as a pre-fabricated chimney system. Should your home have neither at present, it is usually possible to have a pre-fabricated system installed in your home if required.



### Brick/Stone Chimney

(Class 1)

The chimney stack rises well above the roofline and is topped by a traditional chimney pot or gas terminal. This type of chimney relies on the natural circulation of heated air to expel the products of combustion up your chimney.



### Pre-fabricated Flues

(Class 1 & 2)

You will see a metal flue cowl on your roof. Some are all metal whilst others may terminate through a short rectangular pot (but without a chimney stack). These flues create the same circulation of heated air as a brick or stone chimney.

## Balanced Flue

Balanced flues work in conjunction with Gazco's Glass Fronted gas fires only. The appliance is completely sealed from the room into which it is installed (so there are no draughts and heating efficiency is increased) and a twin-wall pipe vents directly to an outside wall.



### Balanced Flue

(No chimney required)

Air for combustion is drawn in through the outer pipe whilst the inner pipe removes the combustion gases to the exterior of the property. Depending on the fire selected, the twin-walled pipe may exit horizontally through an external wall or vertically through the roof. Gazco offers a comprehensive range of balanced flue system components. Please refer to our dedicated Concentric Flue System brochure which can be requested from your retailer or viewed online at [www.gazco.com](http://www.gazco.com).

## No Air Vent Required (UK)



All fires shown with this symbol have the advantage of not normally requiring an air vent\*. Please discuss this in full with your local retailer.

\*Requirements in the Republic of Ireland are different.



# Balanced Flue Options

Gazco offers a comprehensive range of balanced flue system components. Please refer to our dedicated Concentric Flue System brochure which can be requested from your retailer or viewed online at [www.gazco.com](http://www.gazco.com).

Vertical from the top of the appliance

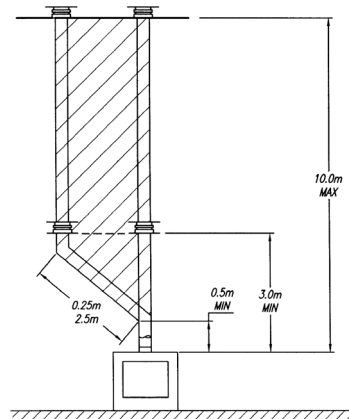

All Studio sizes

Vertical from the top of the appliance then horizontally out

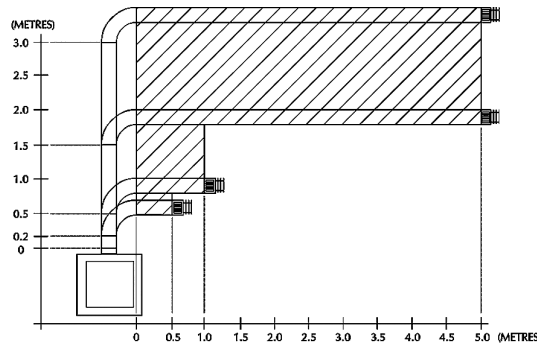

Studio 1

Vertical from the top of the appliance then horizontally out - Studio 2 requires a minimum 700mm rise from the top of the unit

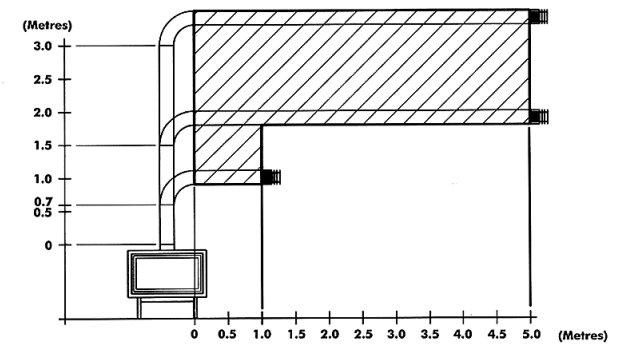

Studio 2

Vertical from the top of the appliance then horizontally out

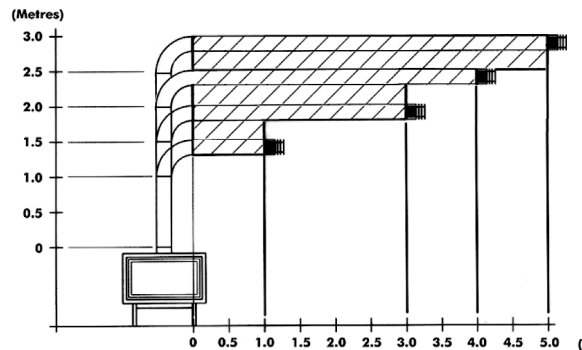

Studio 2 Duplex - LPG

Vertical from the top of the appliance then horizontally out

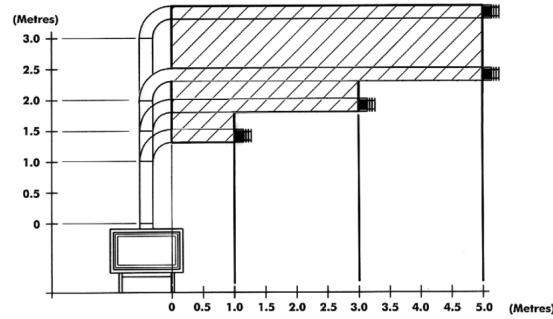

Studio 2 Duplex - Nat Gas

Vertical from the top of the appliance then horizontally out - Studio 3 requires a minimum 1000mm rise from the top of the unit

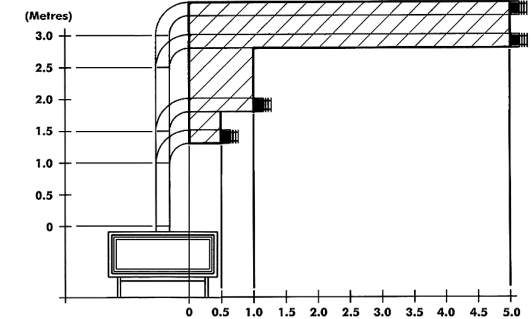

Studio 3

# Important Information

## Technical Specifications

All specifications given in this brochure are approximate. Actual specifications for each individual product will vary according to model. Your Gazco retailer will be pleased to provide any further information you require. Alternatively you may view or download specification sheets from [www.gazco.com](http://www.gazco.com).

## Installation and Safety

Gazco gas fires must be fitted by a qualified gas installer (Gas Safe registered in the United Kingdom or Bord Gáis registered in the Republic of Ireland) who should also verify the proposed site conditions are fully suitable for the product selected. Complete installation instructions for many models can be obtained prior to purchase by viewing or downloading them from [www.gazco.com](http://www.gazco.com). Please note that all parts of these fires, particularly the glass panel in the door, become extremely hot during operation and can result in serious injury and burns if touched. It is therefore recommended that a fireguard complying with BS 8423:2002 is used in the presence of young children, the elderly or infirm.

## Colours/Flame pictures

Owing to variations in studio lighting and printing inks, the finishes/colours of fires illustrated in this brochure may differ slightly from actual models. Before purchasing, please ask your retailer to show you finish/colour samples. Whilst all the flame pictures shown in this brochure are of actual fires, flame pictures may vary depending on the installation, flue conditions and geographical/surrounding features that may effect the efficiency of the flue.

## Care and maintenance

Traditional materials, such as polished steel and brass, tarnish on contact with air, especially when

also exposed to heat. To help minimise this effect, we recommend fires receive regular treatment with suitable proprietary cleaners. Additionally, please remember that gas fires will require servicing annually by a qualified gas installer Gas Safe registered in the United Kingdom or RGII registered in the Republic of Ireland).

## Warranty and Product Improvement

Your Gazco Expert Retailer will provide you with a Two Year Warranty for your new gas fire. This can be extended to a Five Year Warranty provided your fire has been registered with Gazco. The second and subsequent years are dependant on the appliance being serviced 12 months after installation and annually thereafter and exclude certain consumable parts. Fires purchased outside of Gazco's Expert Retailer Network will carry a standard 1 Year Non-Extendable Warranty. Full warranty terms and conditions are available to view at [www.gazco.com](http://www.gazco.com).



Gazco pursue a policy of continuous product improvement, therefore, whilst our products are correct at the time of the photography, we reserve the right to make alterations and amendments. Exact product details should be discussed with your retailer at the time of purchase.

## Air Ventilation for Gas Fires

To comply with gas appliance installation regulations, all Studio 2 and 3 Open Fronted fires and all Glass Fronted Studio 2 fires with a conventional flue require additional ventilation into your room. For further information, please consult either your Gazco retailer or the Gazco Technical Information on our website [www.gazco.com](http://www.gazco.com) to confirm the ventilation required. All other fires featured in this brochure do not require additional ventilation.

Gazco gratefully acknowledges the assistance of the following companies with photographic settings:

**Furnishings and Ornaments:-** [www.amara.com](http://www.amara.com); [www.furniturevillage.co.uk](http://www.furniturevillage.co.uk); [www.fwhomestores.co.uk](http://www.fwhomestores.co.uk); [www.lauraashley.com](http://www.lauraashley.com); [www.faginsantiques.com](http://www.faginsantiques.com); [www.theorangetree.co.uk](http://www.theorangetree.co.uk); [www.habitat.co.uk](http://www.habitat.co.uk); [www.houseoffraser.co.uk](http://www.houseoffraser.co.uk); [www.ashorejewellery.co.uk](http://www.ashorejewellery.co.uk); [www.eclectique.co.uk](http://www.eclectique.co.uk); [www.debenhams.com](http://www.debenhams.com); [www.next.co.uk](http://www.next.co.uk); [www.mokodirect.co.uk](http://www.mokodirect.co.uk); [www.marksandspencer.com](http://www.marksandspencer.com); [www.rocketstgeorge.co.uk](http://www.rocketstgeorge.co.uk); [www.frenchconnection.com](http://www.frenchconnection.com); [www.wayfair.co.uk](http://www.wayfair.co.uk); [www.urbanoutfitters.com/uk](http://www.urbanoutfitters.com/uk); [www.tkmxx.com](http://www.tkmxx.com); [www.homesense.com](http://www.homesense.com); [www.johnlewis.com](http://www.johnlewis.com); [www.coxandcox.co.uk](http://www.coxandcox.co.uk); [www.urbanara.co.uk](http://www.urbanara.co.uk) **Lighting:-** [www.amoslighting.co.uk](http://www.amoslighting.co.uk) **Wood Mantels:-** [www.stovax.com](http://www.stovax.com) **Stone Mantels:-** [www.farmington.co.uk](http://www.farmington.co.uk); [www.bnsp.co.uk](http://www.bnsp.co.uk); [www.grandisson.com](http://www.grandisson.com); [www.rudloe-stone.com](http://www.rudloe-stone.com) **Wood flooring:-** [www.beechbros.co.uk](http://www.beechbros.co.uk) **Tiles & Stone floors:-** [www.originalstyle.com](http://www.originalstyle.com); [www.wallsandfloors.co.uk](http://www.wallsandfloors.co.uk) **Televisions:-** [www.heavitreeradio.co.uk](http://www.heavitreeradio.co.uk) **Plants:-** [www.stbridgetnurseries.co.uk](http://www.stbridgetnurseries.co.uk)  
**Art:-** [www.easyart.com](http://www.easyart.com); [www.desenio.co.uk](http://www.desenio.co.uk)

# Gazco Gas Fires

Reflex 75T Edge with Brick-effect lining and Grafton Mantel in Antique Marble with matching slip-sets and small hearth



Riva2 500 Evoke Glass with White Glass front and Graphite rear with EchoFlame Black Glass lining

Alongside the Studio Gas fire range, Gazco offer the stunning Reflex and Riva2 gas fires. Featuring realistic logs, superb flames and a choice of lining and frame options, these versatile portrait and landscape fires instantly create a focal point which can be tailored to suit your interior.

To view the Gazco Reflex and Riva2 brochures visit [www.gazco.com](http://www.gazco.com) or speak to your local Gazco retailer.



## WIN the cost of your product back!\*

For further home inspiration you can **view real life installations** at our Customer Showcase page and share your thoughts and photos of your new stove or fire installation to enter our draw!

- We will publish your entry on our Customer Showcase
- You will be entered into a draw for the chance to win the cost of your product back
- **Gain a second entry** by registering your product online for your free extended warranty at [gazco.com/registration](http://gazco.com/registration)



"We wanted a stove to give a cosy feel to the room"



"So pleased we chose this gas alternative to a log burning stove"



Instagram - the\_monochrome\_stylist

"It's so easy to start up, with a press of a button!"

View real life installations and submit your review at

[gazco.com/customershowcase](http://gazco.com/customershowcase)

\* Terms and conditions apply. See online for details





Studio 1 Freestanding with White front and bench, Driftwood-effect fuel bed and EchoFlame Black Glass lining



Gazco Limited, Osprey Road, Sowton Industrial Estate, Exeter, Devon, England EX2 7JG

Tel: 01392 261999 • Email: info@gazco.com  
Export Sales: 00 44 1392 261990



Find your Local Expert Retailer



Find your nearest retailer by visiting:  
[www.gazco.com/retailers](http://www.gazco.com/retailers)

Your Gazco stockist:

£3.00

GZSTUDIO1120



gazco.com   

Paper sourced from sustainable forests and printed using vegetable based inks

A member of the Stovax Group © Copyright Gazco Ltd 2020 E & O E